

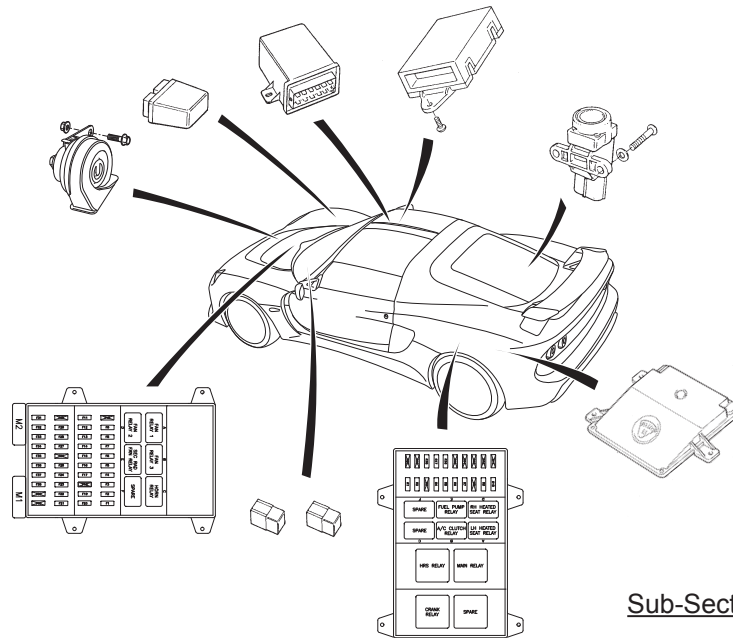

ELECTRICS

SECTION MV



<u>Sub-Section</u>	<u>Page</u>
--------------------	-------------

Vehicle Security Alarm	MV.1	2
Central Door Locking	MV.2	14
Electric Windows	MV.3	16
Ignition Switch/Steering Lock	MV.4	17
Instrument Pack/Driver Information	MV.5	19
Switches & Instruments	MV.6	27
Lotus DPM (Dynamic Performance Management)	MV.7	36
Wiper Mechanism	MV.8	46
Exterior Lighting	MV.9	49
Battery, Battery Cables & Earthing Points	MV.10	55
Harness Routing	MV.11	60
Fuse & Relay Station Locations, Fuse Ratings Inertia Switch & Switch Pack	MV.12	64
Reverse Park Sensor System	MV.13	72
ECM (Electronic Control Module)	MV.14	75
In Car Entertainment	MV.15	80



MV.1 VEHICLE SECURITY ALARM

The Lotus Exige S is fitted as standard with a PFK 457 immobiliser/alarm which includes the following features:

- Lotus branded transmitter key.
- U.K. approval to Thatcham category 1\*.
- 'Dynamic coding' of the transmitter keys; Each time the transmitters are used, the encrypted rolling code is changed to guard against unauthorised code capture.
- Passive activation of immobiliser, central locking and alarm system.
- Ingress protection using sensing switches on the latches of both doors, the front body access panels, and the engine lid/tailgate.
- Selectable cockpit intrusion sensing using a microwave sensor (Only available as an Aftersales option from '15MY VIN FHC10210).
- Self powered siren to maintain protection if the vehicle battery is disconnected.
- Personal protection by 'on demand' activation of the siren.
- Emergency alarm override and transmitter key programming using an alarm/owner specific Personal Identification Number (PIN).

Note, Thatcham category 2 as from '15MY VIN FHC10210 as microwave sensor was no longer fitted at time of production. Thatcham rating can be adjusted to 2/1 with the Aftersales fitment of a microwave sensor, please refer to Technical Service Bulletin TSB 2014/07 for additional information.

**Transmitter Keys**

Two Lotus designed and badged transmitter keys are provided with the car, and combine a mechanical key blade with a three button transmitter unit incorporated into the key head.

*Note: the transmitter is detachable from the key head allowing either one or both to be renewed as service replacements.*

The mechanical key operates the ignition switch, emergency manual door locks and fuel filler cap.

The transmitter operates the electronic immobiliser, alarm system and the central locking.

The two transmitter keys should be kept separate, and a replacement obtained immediately after any loss to ensure that a spare is always available.

**Key/Alarm PIN Identification**

The 4-digit code for the mechanical key, the unique serial number of the immobiliser/alarm, and the vehicle owner's 5-digit alarm Personal Identification Number (PIN), are supplied on plastic tags attached to the key ring of a new vehicle.

In order to allow replacement transmitter keys to be programmed, it is essential that these numbers are recorded and kept safely by the owner with the vehicle documents.

It is also recommended that the dealer stress this issue to their customers and, in the interests of customer service, keep a record in their own database.

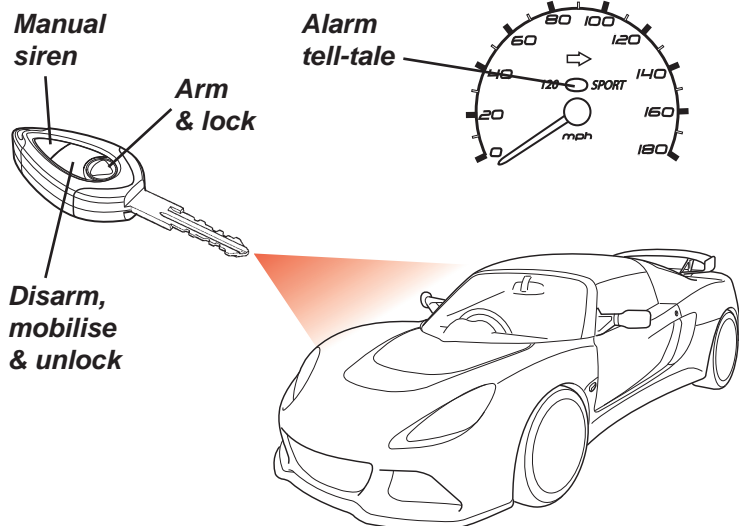

**5 Digit PIN for alarm transmitter**

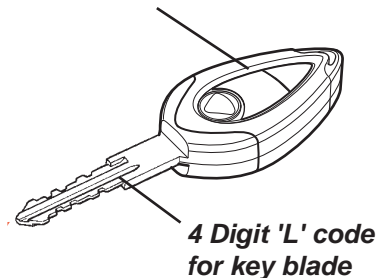

**Obtaining Key or Alarm Identification Numbers**

In the event that the customer has not retained the plastic tags with key/alarm details and dealer records have not been kept, then the information can be obtained from the Lotus Cars Aftersales Department using Archive Search - Security Codes Form number A4-A-5301.

The form lists details of information required to complete a successful search as well as costs for the services and contact details within the Lotus Aftersales Department, the form can be downloaded from the Lotus Dealer Portal at: <http://dealers.lotuscars.com>. From the homepage go to the Aftersales category and select the form from the 'Download Form Documents' section.

**Replacement Keys**

*Uncut Keys:* Additional or replacement keys may be purchased uncut/uncoded from the Lotus Aftersales Department under part number A120H0008S and will be supplied with a blank mechanical blade for copy cutting to an existing key.

*Cut Keys:* Alternatively, for authorised Dealers and Repairers reporting directly to the Lotus Cars Aftersales Department, a key cut to its 4 digit 'L' key code may be ordered from Bolton Lock Company, using Lotus Key Cutting/Transmitter order form LSL482 the form can be downloaded from the Lotus Dealer Portal at: <http://dealers.lotuscars.com>. This can also be downloaded from the Lotus Dealer Portal, from the homepage go to the Aftersales category and select the latest version of the form from the 'Download Form Documents' section.

Note: Authorised Dealers and Repairers reporting to a Lotus Distributor should contact their relevant parts personnel to order cut keys

**Vehicle Lock Set Renewal**

The complete vehicle lock set can be renewed whilst still retaining the original alarm systems 5-digit PIN. Lock sets can be obtained directly from the Lotus Cars Aftersales Department, refer to the Lotus Service Parts List for the latest/correct part number(s).

A replacement lock set will have a new 4 digit 'L' key code, please ensure to retain this new number on any relevant database, inform the vehicle owner of the new number as well as the Lotus Cars Aftersales Department using Notification - Lock/Alarm Replacement Form number A4-A-5304. This can also be downloaded from the Lotus Dealer Portal, from the homepage go to the Aftersales category and select the latest version of the form from the 'Download Form Documents' section.

**Replacement Transmitter Fobs**

A replacement transmitter fob can be obtained directly from the Lotus Cars Aftersales Department, refer to the Lotus Service Parts List for the latest/correct part number.

Note: this will require matching to the vehicles alarm system using the 5-digit PIN,

Further information of all key and alarm fob availability as well as any specific ordering procedures can be obtained by downloading the 'Key & Alarm Transmitter Guide' document number LSL483. The latest version can also be downloaded from the Lotus Dealer Portal.



Alarm Operation

Disarming the Alarm/Unlocking: When approaching the car, it is likely that the vehicle is locked and the alarm armed. The alarm red tell tale lamp in the speedometer face will flash once every 3 seconds.

To disarm the alarm and unlock the doors:

- Press the central, unlock, button on the transmitter key. The first press will unlock just the driver's door. Two presses in quick succession will unlock both the driver and passenger doors.
- This command will be acknowledged by a double flash of the hazard lamps.
- The engine will be mobilised (see below).
- The interior lamp will fade on, and remain lit for up to 2 minutes (if set to the 'courtesy' position).
- The alarm tell tale will be extinguished.

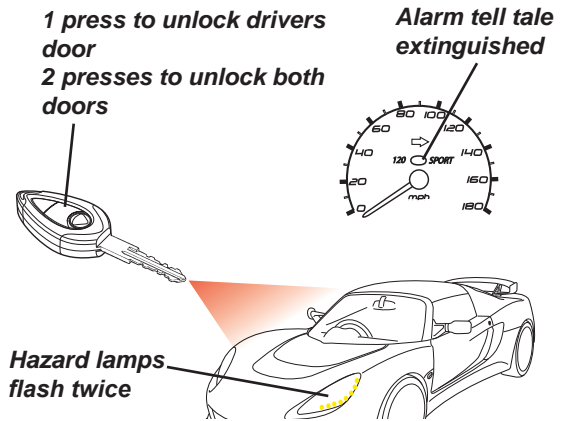

If a door is not opened within 2 minutes, the doors will passively re-lock and the alarm system re-arm.

Passive Immobilisation

In order to provide a measure of automatic vehicle security, independent of any driver initiative, the system will 'passively' immobilise the engine's cranking and fuel pump circuits after the ignition has been turned off for 40 seconds, or a similar period has elapsed since the last mobilising command.

With the ignition off, the alarm tell tale will indicate that immobilisation is in effect by briefly flashing every second. With ignition on, immobilisation is indicated by a continuously lit tell tale.

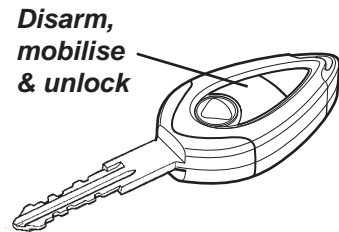

To mobilise the car (i.e. allow engine starting) with ignition on or off, press once the transmitter centre button; the alarm tell tale will be extinguished.

Arming the Alarm/Locking the Doors

To lock the doors and arm the alarm, remove the ignition key, close both doors, and check that the engine lid/tailgate and body front access panel are secure:

- Press once the raised logo button on the transmitter fob.
- This command will be acknowledged by a single flash of the hazard lamps.
- Both doors will be locked, the engine immobilised and the alarm system armed. A settling period of 40 seconds must expire before the ingress sensors become active.
- The alarm tell tale will repeatedly triple flash.

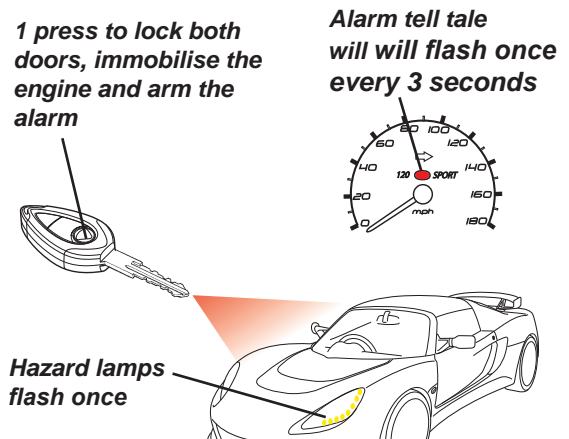

Note:

- If the system is armed when a door is not fully shut, three **triple** beeps will sound as a warning and the doors will not be locked. Opening a door will *not* trigger the alarm.
- If the system is armed when the engine lid/tailgate or the front access panel is not fully closed, three warning **double** beeps will be heard, and the doors will not be locked. Opening a door in this instance *will* trigger the alarm.
- If one transmitter is used to disarm the alarm, and a second transmitter to re-arm, a system test mode will be initiated, and operational variations will occur. Allow an undisturbed period of 2 minutes to elapse to restore normal operation.

When fully armed, and after the settling period of 40 seconds has expired, the alarm will be triggered by any



of the following actions:

- Interruption of the car battery power supply or siren cables.
- Energising the ignition circuit ('hot wiring').
- Opening a door;
- Opening the engine lid/tailgate or a front access panel.
- Movement detected within the cabin (unless de-selected).

If the alarm is triggered, the hazard warning lamps will flash and the siren sound for a period of approximately 30 seconds before closing down and resetting, ready for any further triggering input.

If a trigger is continuously present (e.g. door left open), the alarm will repeat for a maximum of eight 30 second cycles before excluding the triggering sensor for the remainder of the armed period.

To silence the siren, press once the central, disarm button on the transmitter key. If necessary, press a second time to disarm the alarm.

**Hazard warning lights flash and siren activated**

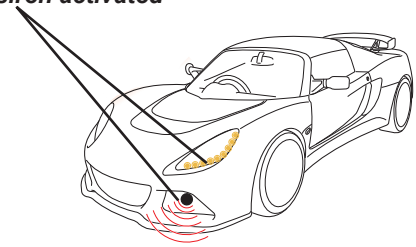

**Alarm Tell Tale Summary**

- Tell tale off; Alarm disarmed, engine mobilised.
- Tell tale on; Immobilised with ignition on.
- Brief flash every second; Immobilised with ignition off.
- 1 flash every 3 seconds. Alarm armed.

**Cockpit Intrusion/Interior Movement Sensor**

A microwave sensor is mounted behind the cabin rear bulkhead trim panel, and is able to detect substantial physical movement within the cockpit, and trigger the alarm. Microwave transmissions are blocked by metal objects, so it is important not to shield the signal by placing such items on the bulkhead ledge.

**Disabling the Interior Movement Sensor**

If an animal is to be left in the vehicle, or if for any other reason it is desired to exclude the interior movement sensor when the alarm is set,

Disabling procedure:

- Press once the transmitter logo button in the normal way to set the alarm, and then press a second time (within 2 seconds) to exclude the interior movement sensor.
- A single beep will be heard as confirmation.

**Press twice within 2 seconds to disable intrusion sensor**

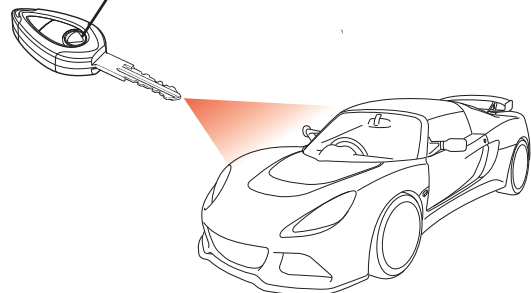

Note: This exclusion will be automatically cancelled when the alarm is disarmed.



**Microwave/Intrusion Sensor (if fitted)**

The sensitivity of the sensor is factory set for the Exige, and the adjustment screw has been sealed and so cannot be adjusted.

The sensor is accessible after removal of the cabin rear bulkhead trim panel, refer to service notes section VE.11 for further information

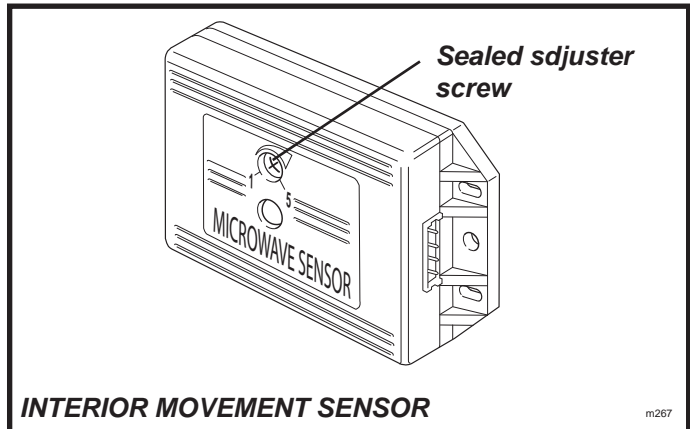

**Manual Activation of Siren**

If desired it is possible to manually activate the siren at any time when the ignition is off.

- Press for 3 seconds the transmitter auxiliary (3rd) button.
- The siren will sound, and the hazard lamps flash for a period of 30 seconds.
- To stop the siren, press once any of the transmitter buttons.

Note: Manual siren activation will not affect the status of the alarm arming.

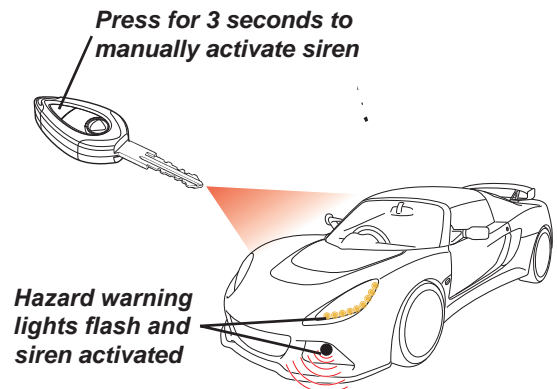

**Transmitter Key Battery Replacement**

The transmitter keys will normally operate within a range of 5 metres from the car, but this may be reduced by the presence of other radio signals in the vicinity.

The transmitters are powered by a long life 3V Lithium battery, type CR2032, which with normal use should last for 3 years.

To ensure continuity of operation, it is recommended to renew the batteries every 12 months

To replace battery:

- Using a small screwdriver, prise open the back panel of the key case using the slot by the keyring hole.
- Remove the old battery and wait for 10 seconds before inserting the new battery with +ve sign uppermost, and holding the battery only by the periphery.
- Refit the back panel, engaging the retaining tongue, and pressing firmly to engage the clip.
- The transmitter should now operate normally.

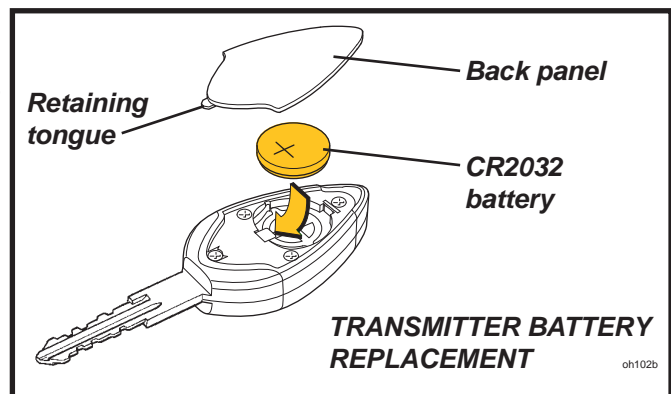



**Disconnecting the Vehicle Battery**

In order to prevent the alarm being triggered, before disconnecting the vehicle battery, ensure that the alarm is disarmed. Please refer to sub-section MV.10 for further information.

**Emergency Disarming/Mobilising**

If the key head transmitters are lost or damaged, the alarm system owner's 5-digit alarm PIN may be used to disarm the alarm and start the engine **provided that** the cabin is accessible, and a correct mechanical key blade is available.

Note that if the alarm is armed, accessing the cabin, or turning on the ignition will trigger the alarm until completion of this emergency process.

Emergency procedure:

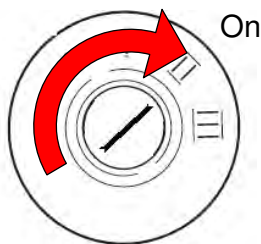

Turn on the ignition. The alarm tell tale will light.

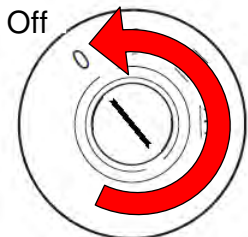

Within 10 seconds, turn the ignition off; the tell tale will begin to flash. After a number of flashes corresponding to the first digit of the PIN, for example, 23121.

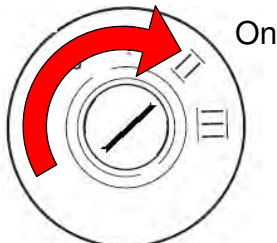
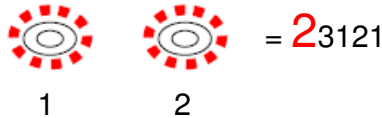

Turn on the ignition

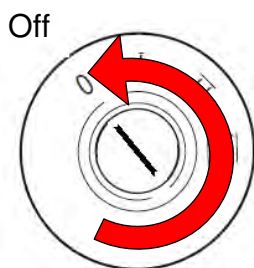

Turn off the ignition and after a number of flashes corresponding to the second digit of the PIN, turn on the ignition.

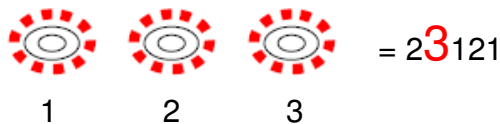

Repeat this process until all 5 digits have been completed.

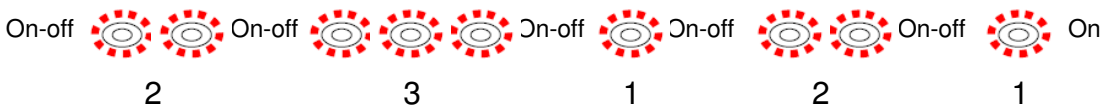

If the PIN is entered correctly, the alarm will now be overridden and the engine mobilised.

Note that 10 flashes correspond to a zero digit.



**Programming Additional Transmitters**

A maximum of 6 transmitters may be programmed to the car, any thereafter overwriting the first to have been programmed.

There are 2 steps to the programming procedure which are:

1. Setting the vehicle alarm system into emergency disarming/mobilising mode as shown on previous page
2. Programming additional transmitters

*Procedure:*

Enter the PIN as detailed in the emergency disarming process previous, followed by the additional two digits 1, 1.

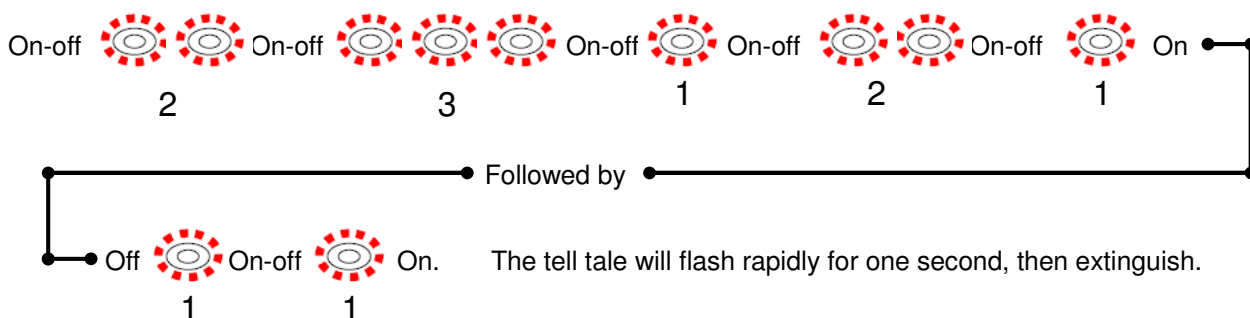

Within 8 seconds, press any button on the transmitter to be programmed.

The tell tale will then pulse rapidly and the siren will beep.

Within 10 seconds press any button on the next transmitter to be programmed (if applicable), and repeat this process for all remaining transmitters.

When all transmitters have been programmed, wait for 10 seconds, or turn off the ignition.

Note that 10 flashes correspond to a zero digit.

To disable a lost or stolen transmitter from the system, use the above procedure to programme 6 transmitters, if necessary repeatedly reprogramming the same transmitter if less than 6 programmed transmitters are to be used.





**Trigger Report Back and Feature Selection**

A facility is provided to identify the source of an alarm triggering event (trigger report back), as well as allowing certain features of the system to be selected or de-selected. The same procedure described above to input a PIN is used, but in this case to input the programming code '123'; the tell tale will then flash rapidly for 1 second, then remain lit. Commencing within 10 seconds, continue this procedure to input the two digits of the feature code, after which the tell tale will flash rapidly for 1 second then beep once or twice to indicate the new status of that feature; one for 'ON', twice for 'OFF'. Selection will alternate each time that feature code is entered. Note that within 10 seconds, a second feature code (or repeat) may be selected from this point by entering only the 2-digit code. To exit programme mode, simply wait for 10 seconds.

Feature	Code	Default	1 Beep	2 Beeps
Revert to defaults	123 00			
Trigger report back	123 11	see below		
Unlock with ignition	123 33	OFF	ON	OFF
Lock with ignition	123 34	OFF	ON	OFF
Selective door unlock	123 41	ON	ON	OFF
Audible tones*	123 61	OFF	ON	OFF
Lock with auto re-arm	123 87	ON	ON	OFF
Door open audible warning	123 88	ON	ON	OFF

\* When selected, a single beep will sound when the alarm is armed, and a double beep when disarmed. To silence for a single activation, press briefly the transmitter auxiliary (3rd) button prior to pressing the arm or disarm button.

*Trigger report back:* After the code 12311 has been entered, the tell tale flashes out a code(s) to indicate the source of the alarm trigger:

No. of flashes	Triggering sensor
1	Microwave movement sensor
2	Door, bonnet or boot lid
3	Ignition energisation
4	Manual siren activation

**Quick Test**

To facilitate testing of the alarm system, the unit can be placed into a 'Quick Test' mode by arming the alarm with one transmitter key, and disarming with another. In this mode, the system will shorten the siren time to 2 seconds, the immobiliser arm time to 5 seconds, and the settling time to zero. To exit this mode, simply wait for 2 minutes without any further inputs.

Note that in Quick Test mode, any movement detected by the microwave sensor will trigger only the tell tale and not the siren. The 2 minute timer will not be extended.

**Component Location**

The alarm system components are located as follows:

- Electronic Controller/Immobiliser: Mounted on top of the scuttle beam at LH extreme end. Accessible after removal of fascia top.
- Siren Unit: Mounted on LH underside of inner crash structure. Accessible only after removal of front undertray.
- Microwave Sensor: Mounted centrally on cabin rear bulkhead, beneath trim panel.
- Engine Lid Sensor: Mounted on luggage compartment bulkhead, alongside latch.
- Front Access Panel Sensor: Mounted on brackets fixed to topshell at outboard edge of aperture.
- Central Door Locking: Mounted on top of the scuttle beam at RH extreme end. Accessible after removal of fascia top, see next page for details.

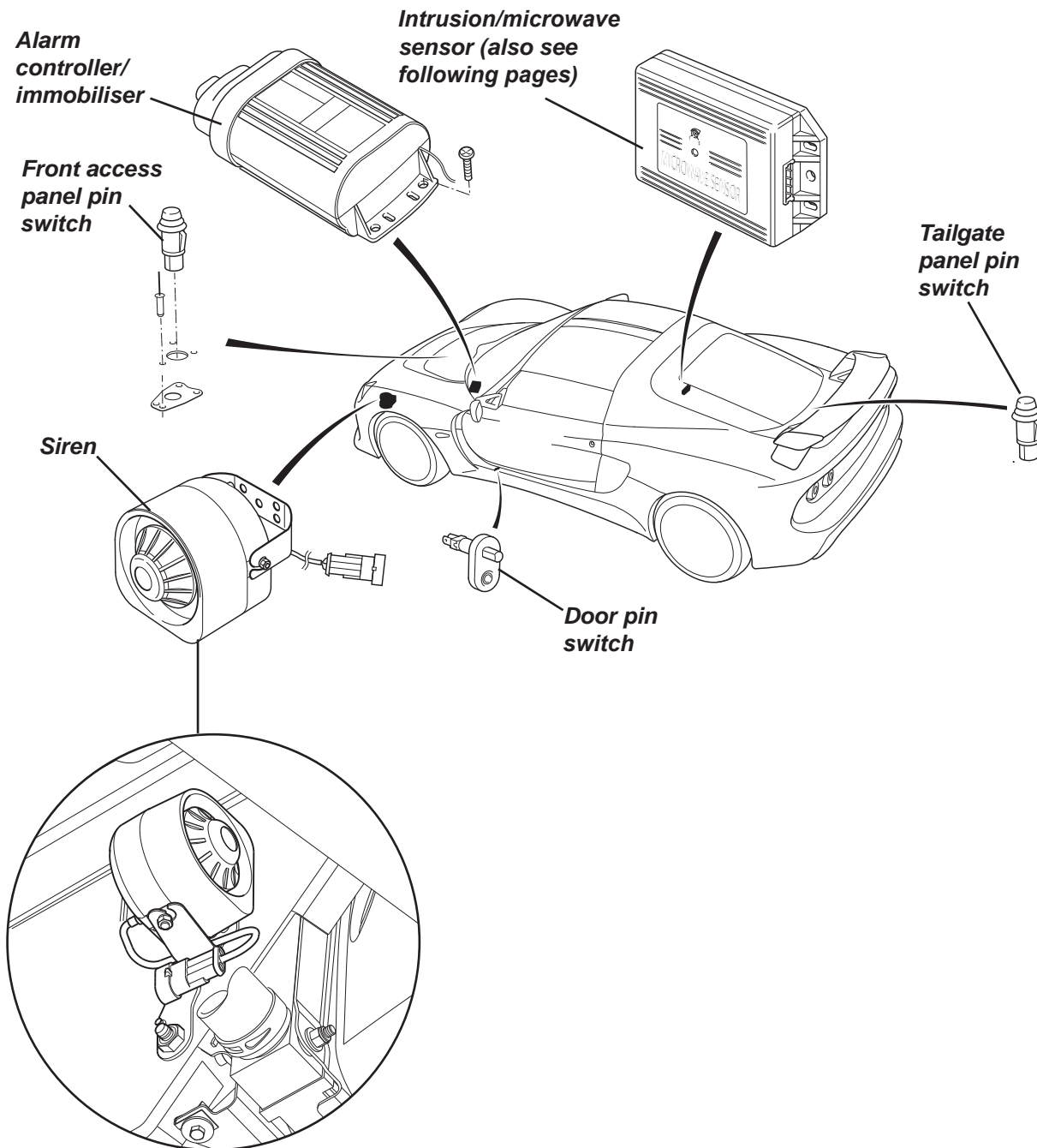



**Deletion of Microwave Sensor**

*(Text below extracted from Technical Service Bulletin TSB 2014/07 issued 04/09/14)*

The microwave sensor installed as part of the PFK 457 alarm system is no longer be fitted as production standard equipment on any Exige S variants from '15MY VIN number FHC10210 inclusive.

Although the rest of the alarms functionality will not change the cabin intrusion detection feature will no longer operate with the arming of the alarm/locking the vehicle doors using the key fob.

This means that the alarm system will not detect movement from within the cabin that can be generated by scenarios such as a broken door glass or deliberate entry into the vehicle via an open door glass, soft top etc.

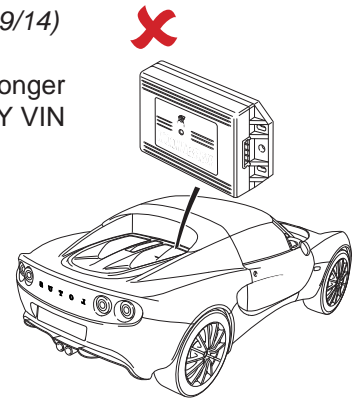

Because of the deletion of the cabin intrusion feature from the alarm system, all Exige S models from '15MY VIN FHC10210 onwards have been re-categorised from U.K approval Thatcham category 1 to Thatcham category 2.

Although the microwave sensor module is not fitted, the main alarm module remains the same with the harness and wiring connector for the sensor still positioned behind the rear bulkhead trim panel. If requested by the owner, a microwave sensor can be retrospectively fitted to the vehicle.

Fitment of the microwave sensor will raise the U.K. approval from Thatcham Category 2 to Thatcham Category 2/1 - Electronic Alarm Upgrade. This is defined as restoring the vehicle to meet the Category 1 criteria by performing the upgrade work required outside of the time of production and may potentially lower the vehicles insurance premium as compared to a Category 2 level.

**Retrofitment of Microwave Sensor**

Procedure:

- 1. Remove the rear bulkhead trim panel.

Note: The microwave sensor connector is integral to the main vehicle harness and so is still fitted but has been secured by tape to the interior light wiring harness.

- 2. Identify the interior light harness and remove the tape securing the sensor connector to it.

Note: Dependent on the vehicle build date post '15MY VIN FHC10210 the foil shielding may still be fitted to the rear bulkhead panel underneath the self adhesive bulkhead NVH dampening sheet. If the foil shielding has been fitted then a portion of it will be visible through a rectangular cut out within the dampening sheet.

**IMPORTANT:** The microwave sensor MUST NOT be fitted directly onto the bulkhead panel; the sensor foil shielding sheet must be fitted directly against the bulkhead to ensure that the sensor does not detect water ingress movement i.e., rain drops etc that may enter the engine bay via the engine cover as this may produce unwanted alarm activations.

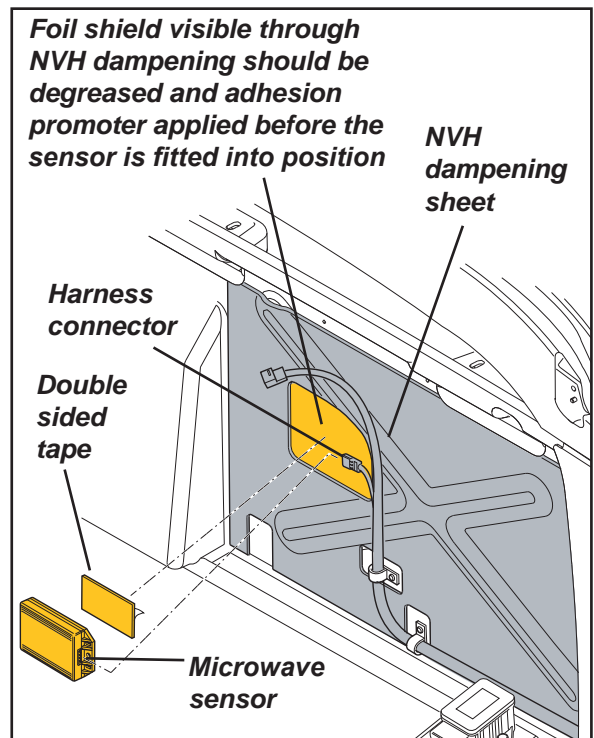



3. If the foil is visible then clean the bonding path area where the sensor will be positioned by applying a degreaser and cleaning agent such as Betaclean 3900, wipe over the bond path & then dry wipe immediately with a lint free tissue or similar (excluding industrial rags/cloths).

If the foil is not visible through the NVH dampening panel then please follow the foil fitting instructions shown below after microwave sensor fitment.

4. Using an adhesion promoter such as 3M 4297UV, prime the visible foil area.
5. Apply 50mm of a suitable double sided tape to the rear surface of the microwave sensor casing, ensure that the complete rear surface is covered, even if that means 2 or more 50mm strips are required.
6. Fit the microwave sensor on the primed and bonded foil centrally within the rectangular aperture of the NVH dampening sheet.

Note: Sensor must be fitted in the correct orientation so that the 'Microwave Sensor' text embossed on the casing is facing outwards and is the correct way up (not upside down)

7. Ensure the harness is feed through both 'P' clips positioned below the sensor
8. Connect the main harness connector to the Microwave sensor terminal located on the RH side of the casing and is fully engaged i.e. has clicked home into position.

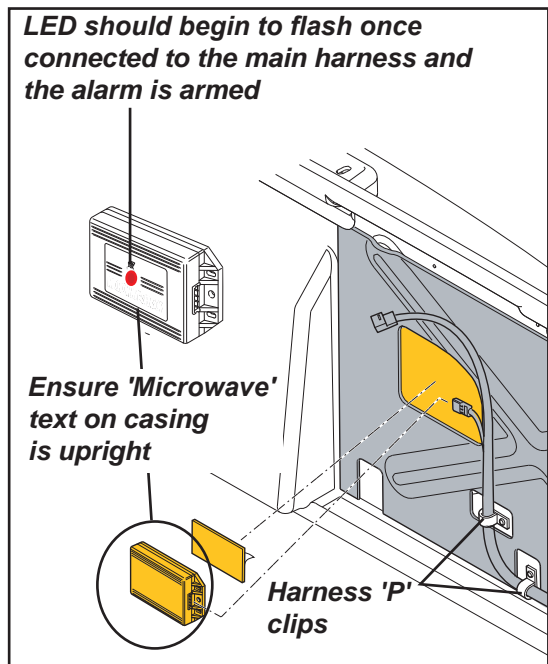

Before refitting the bulkhead panel trim, test the functionality of the sensor by arming the vehicle alarm and then wave your hand at close proximity to the microwave sensor.

If working correctly the red LED (Light Emitting Diode) in the centre of the casing should flash as your hand passes over it.

Once correct operation of the microwave is confirmed, refit the interior bulkhead panel and seats

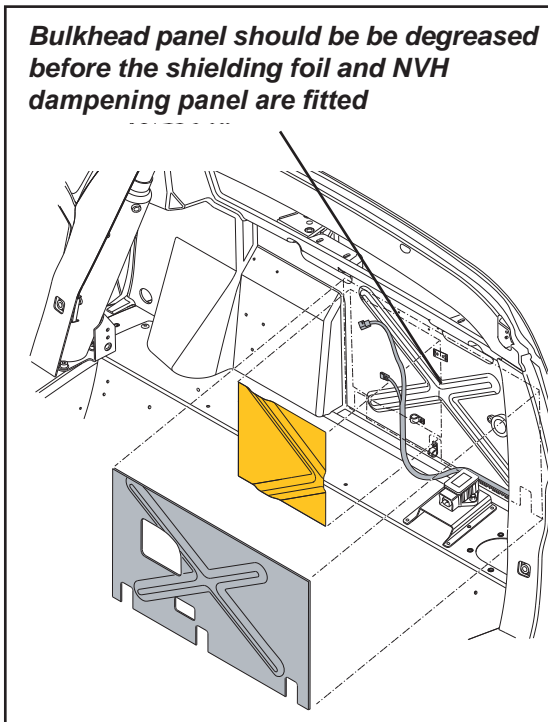

**Microwave shield foil fitment**

Procedure:

1. Remove main harness from bulkhead 'P' clips to provide a clear working area.
2. The NVH dampening pad may have still have been fitted, if so carefully peel off the bulkhead panel
3. Clean the bonding path area where the shielding foil and NVH dampening pad will be positioned by applying a degreaser and cleaning agent such as Betaclean 3900, wipe over the bond path & then dry wipe immediately with a lint free tissue or similar.
4. Peel off approximately 25mm of the LH edge of the shields adhesive backing.



5. Position the 'sticky' edge of the shield just inboard of the raised bulkhead section.
6. Position the bottom edge just below the sideways 'P' clip
7. Position the top edge of sheet just below the bulkhead trim bracket.
8. With the LH edge stuck to the panel carefully remove the rest of the foil backing whilst smoothing it along the bulkhead panel contours and 'X' patterned section.
9. The foil should be smoothed to bond against all the contour lines of the panel ensuring that no voids or air bubbles have been created.
10. If in good condition refit the NVH dampening pad over the shielding foil ensuring the LH and top edges are fitted just inboard of the raised bulkhead section and just below the bulkhead trim bracket and that the manufactured cut outs are positioned correctly around the bulkhead 'P' clips (or fit a new pad if required).

Continue from step 3 of microwave sensor fitment on previous page to adhere the sensor to the shielding foil.

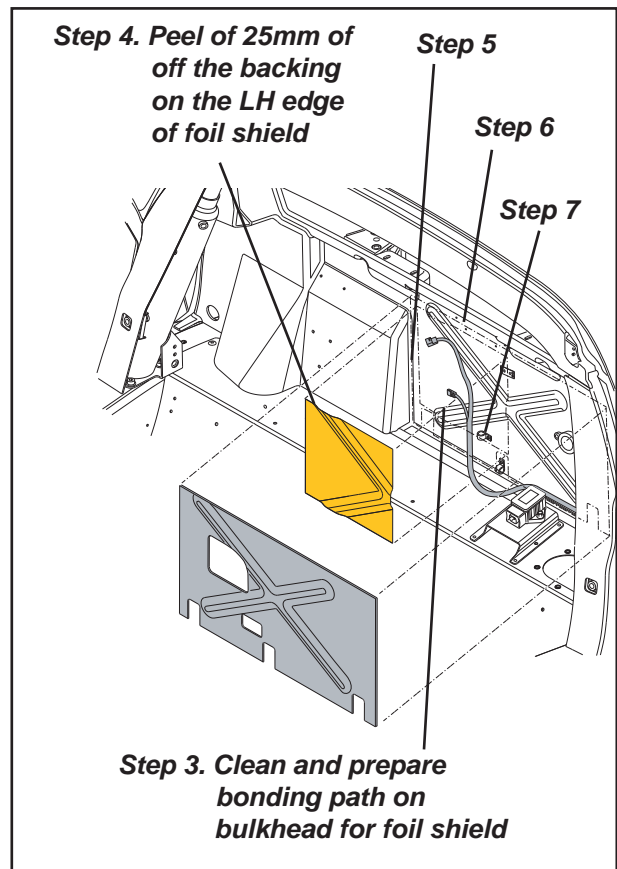



MV.2 - CENTRAL DOOR LOCKING

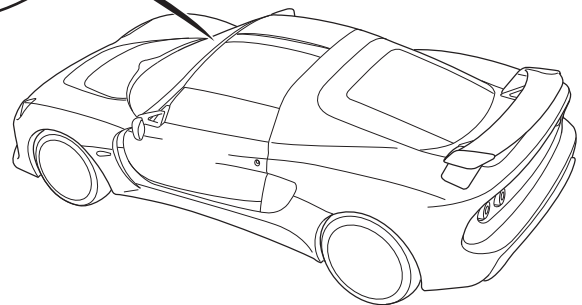
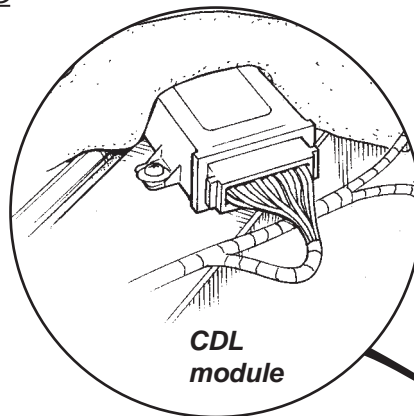

The CDL (Central Door Locking) module is mounted on the top of the scuttle beam at the extreme end on the RH side, accessible after removal of the fascia top trimmed panel and face level vent trunking. Refer to service notes section VE.8 for further information.

A battery feed for the CDL system is provided from the main fusebox, fuse number 34 (7.5A).

The central door locking (CDL) operates on the driver's and passenger's doors in conjunction with the security alarm system, which includes CDL circuitry in the PFK 457 alarm controller. See sub-section MV.1 for information on locking the vehicle and alarm activation.

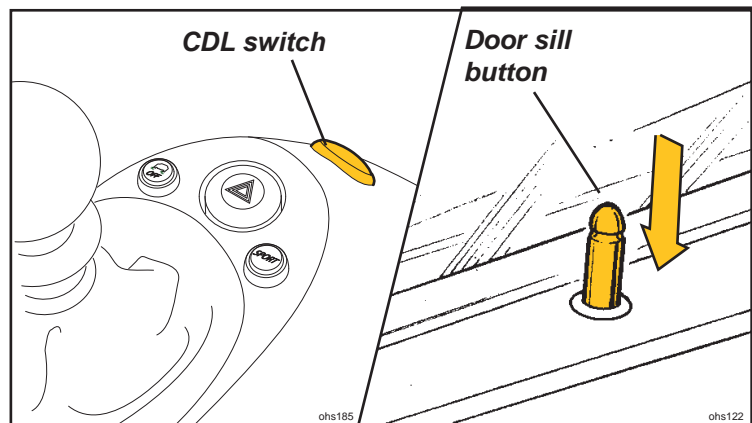

If it is desired to lock the doors from inside the vehicle, a CDL rocker switch is provided on the front of the gear lever shroud which should be pressed to the right to lock both doors with or without the ignition switched on.

Alternatively, the doors can be locked individually by depressing the button at the rear end of each door sill. Note that whichever locking method is used, the doors will be 'deadlocked' such that the interior door release handles are inoperative.

See sub-section MV.1 for information on unlocking the vehicle and alarm de-activation. Alternatively, from inside the car, press to the left the rocker switch on the gear lever shroud to unlock both doors, or raise the sill button on each door.

Note that in the event of a vehicle collision which causes the safety inertia switch to be tripped, the doors will automatically be unlocked.

**Notes:**

- In the event of a flat vehicle battery, the central door locking will not operate.
- The doors can be unlocked from outside only after removing the front clamshell access panel, (see service notes section BT.2 for further information) and providing a 12 volt supply to the auxiliary power point.
- To lock the car with a flat or disconnected battery, use the mechanical key in each exterior door button to disconnect each release button from the latch. This technique does not 'deadlock' the interior release handles, but does allow continued key access to the car until restoration of battery power.
- To deadlock the car with a flat vehicle battery, or without the use of the transmitter or mechanical key, close and lock one door using the sill button, and for the second door, hold the exterior release button pressed in and depress the sill button before closing the door. Access is now available only on restoration of electrical power.

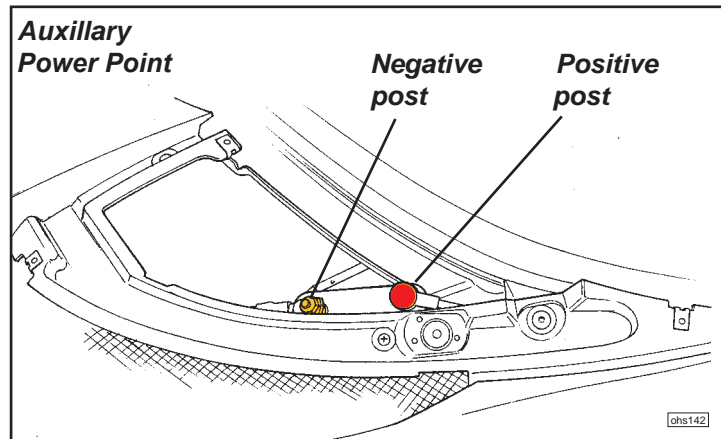
**Door Locking Actuator**

A CDL actuator is screw fixed to the door shell below the latch mechanism, and uses a link rod which passes through the innermost hole on the latch lever, before continuing upwards to the door sill button. For replacement details, refer to sub-section BT.12.



MV.3 - ELECTRIC WINDOWS

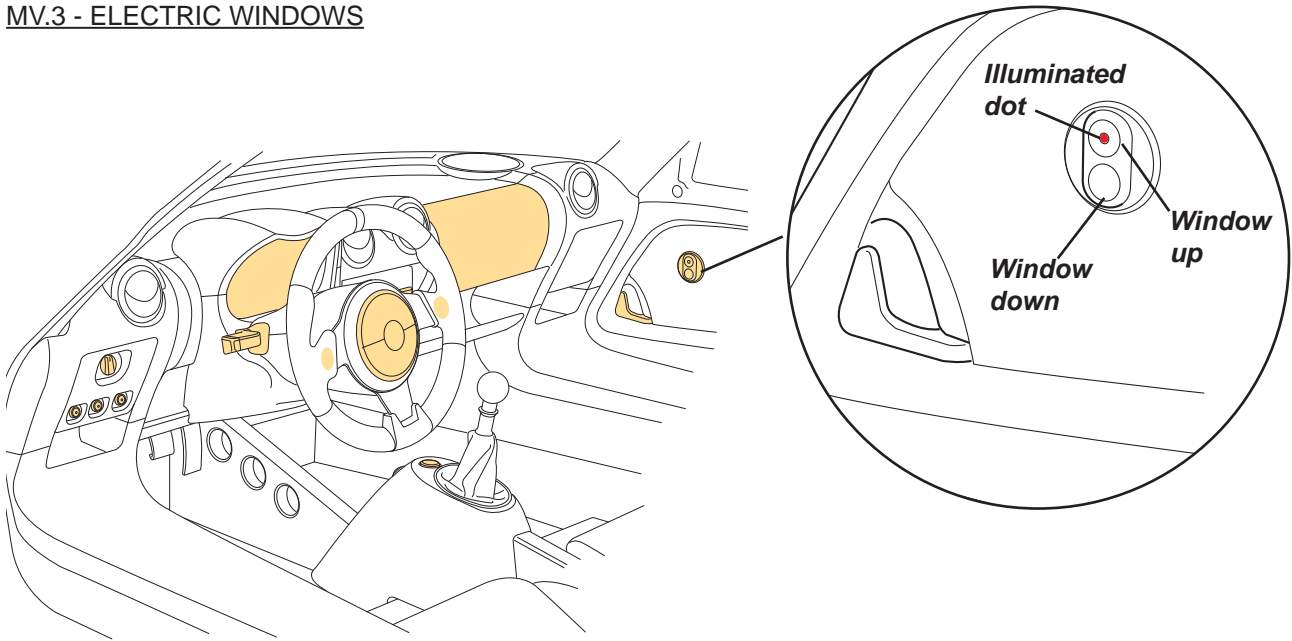

Switches for the electric windows are mounted in the front of the door trim infill panels, and are operative only with the ignition switched on. To help locate the switches in the dark, an illuminated dot is provided in the 'up' button which glows amber when the lights are switched on.

To lower a window, switch on the ignition and press the lower, dished end of the switch in the relevant door. Release the switch to stop window movement. To raise a window, press the upper, domed end of the switch. The electric window lift mechanism uses an electric motor and winder drum driving a steel cable around top and bottom guide pulleys to a lift block. The window glass is fixed to the lift block which is guided by a vertical rail.

The door harnesses to support CDL and electric windows are routed to the scuttle area via a grommet in the 'A' post area ahead of the door hinge post. Power for the window motors is provided via two 20A fuses from the main fusebox, (F6 drivers, F7 passengers).

Also refer to section BT.11 for additional information on the electric door window motor and mechanism.

The window switch is fitted within a plastic bezel, retained with integral spring clips. The bezel is in turn fixed to a retaining bracket clamped to the rear surface of the door trim insert panel.

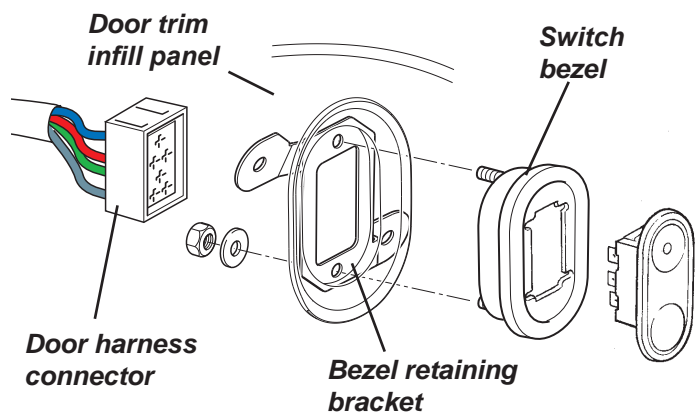

m336

Although it may be possible to remove the switch from the bezel in situ, the door harness may restrict how far the switch can be withdrawn, therefore the door trim, complete with infill panel and switch should be removed from the door and the door harness connector disconnected from the back of the switch. The switch can then be removed from the bezel trim. Refer to service notes section VE.1 for further information on door trim panel removal.





MV.4 - IGNITION SWITCH/STEERING LOCK

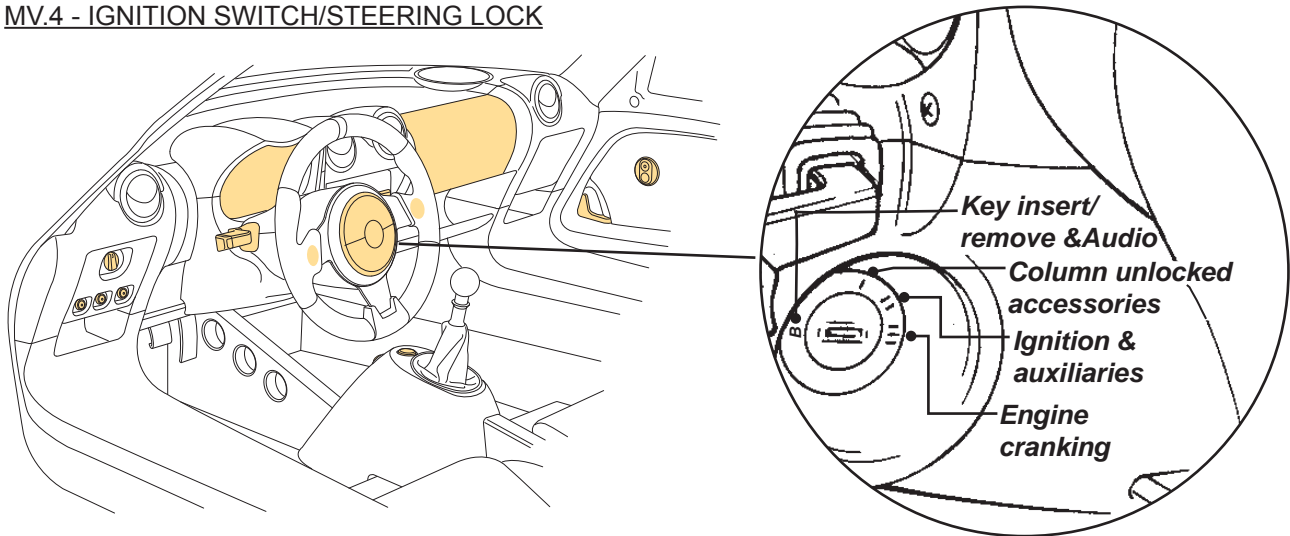

**Ignition Switch/Steering Lock**

Located on the right hand side of the steering column. With the key out of the switch, the steering column is locked, and the following electrical circuits will function:

- Locking and alarm system.
- Horns.
- Hazard warning lamps.
- Sidelamps and headlamps.
- Interior lamps.
- Automatic operation of cooling fans and re-circulation pump.

B With the key inserted into the switch at position 'B', the audio system is available in addition to the above.

I To unlock the steering, turn the key clockwise to the 'I' position. If the key is reluctant to turn, wriggle the steering wheel to ease the load on the steering lock. At this 'accessories' position, the following electrical circuits will function in addition to those above:

- Door windows.
- Windscreen wiper and washer.
- Interior fan.
- Cabin auxiliary power socket.
- Automatic only: P - Park is automatically selected.

II Turn further clockwise to the 'ignition' position to activate all remaining electrical systems (note that some circuits require the engine to be running). Refer also to automatic immobilisation details in sub-section MV.1.

III Ensure the key is fully pushed in the lock and turn further clockwise to 'III' against spring pressure to operate the starter motor. As soon as the engine starts, allow the key to return to position 'II'

DO NOT leave the ignition switched on for long periods without the engine running, since although the engine ignition system itself draws no current when the engine is stopped, a battery drain will occur through other circuits even when auxiliary equipment is not being used. For security reasons, and to guard against battery drain, always remove the key when leaving the car.

**⚠ WARNING:**

- Do not push or tow the car unless the key is first used to unlock the column and is then left in the lock.
- Never withdraw the key until the vehicle is stationary.
- To reduce the risk of theft, or danger to a child remaining in the vehicle, always remove the key when leaving a parked car.

**Ignition Switch**

To reduce the risk of unwanted attempts of bypassing the ignition circuit, the main harness connector to the switch can only be removed (without causing damage) with the key inserted into the lock barrel and turned to position 'I'

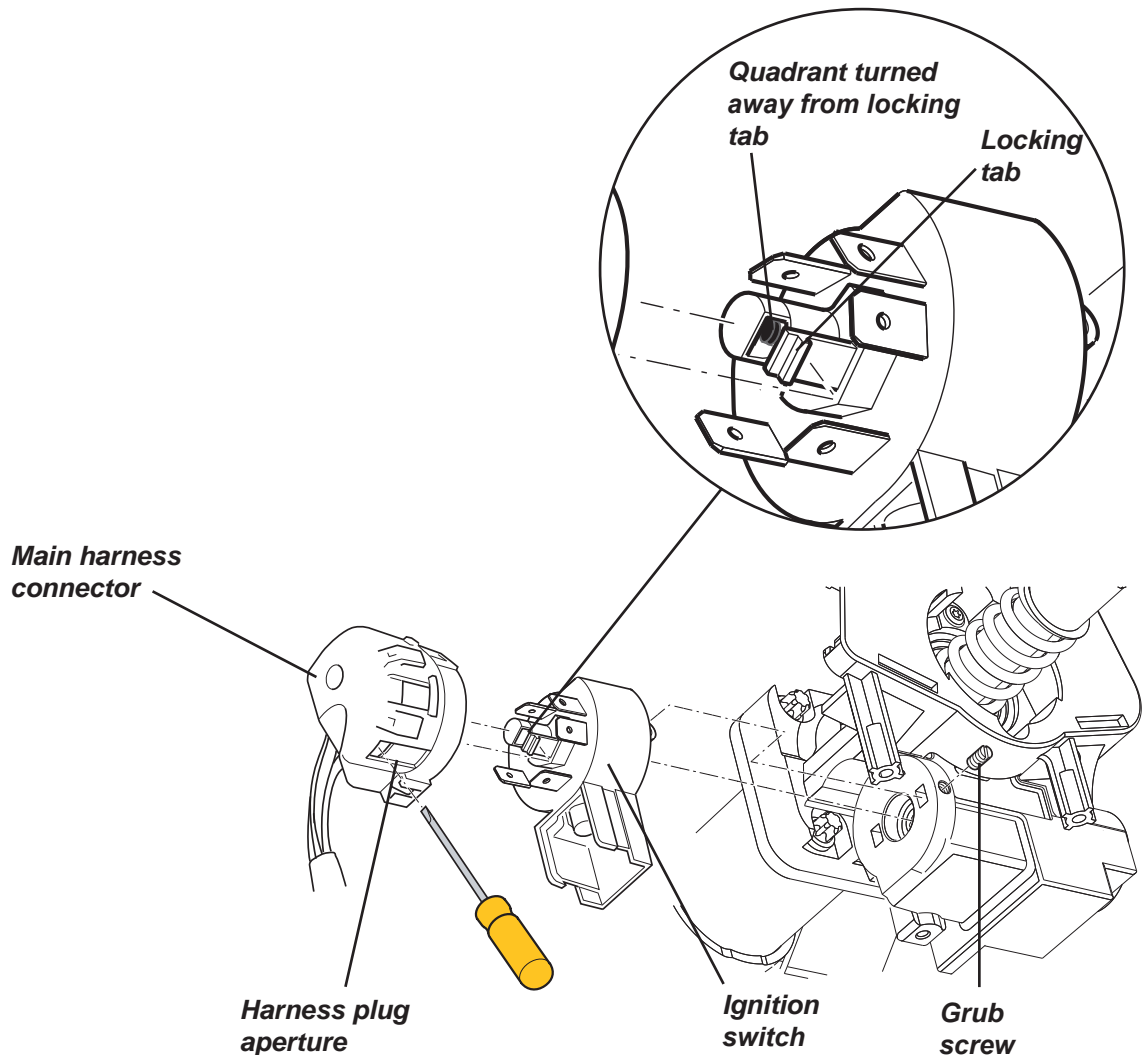
**Removal:**

Remove the upper and lower steering column shrouds, refer to service note section VE.4 for further information.

Turn the key to position 'I',

Note: Turning the key rotates an internal shaft within the switch. A quadrant on the end of the shaft is now turned away from the side of the switches integral harness plug connector locking tab. This allows the locking tab to be pushed in releasing it from the harness connector retaining lug.

Using a suitable screwdriver, carefully feed it into the aperture in the harness plug as shown in the illustration.

Carefully push the screwdriver against the locking tab whilst gently pulling the harness plug away from the switch.

The switch can now be removed by releasing the grub screw retaining it to the column housing.



MV.5 - INSTRUMENT PACK/DRIVER INFORMATION

Tell Tale Lamps

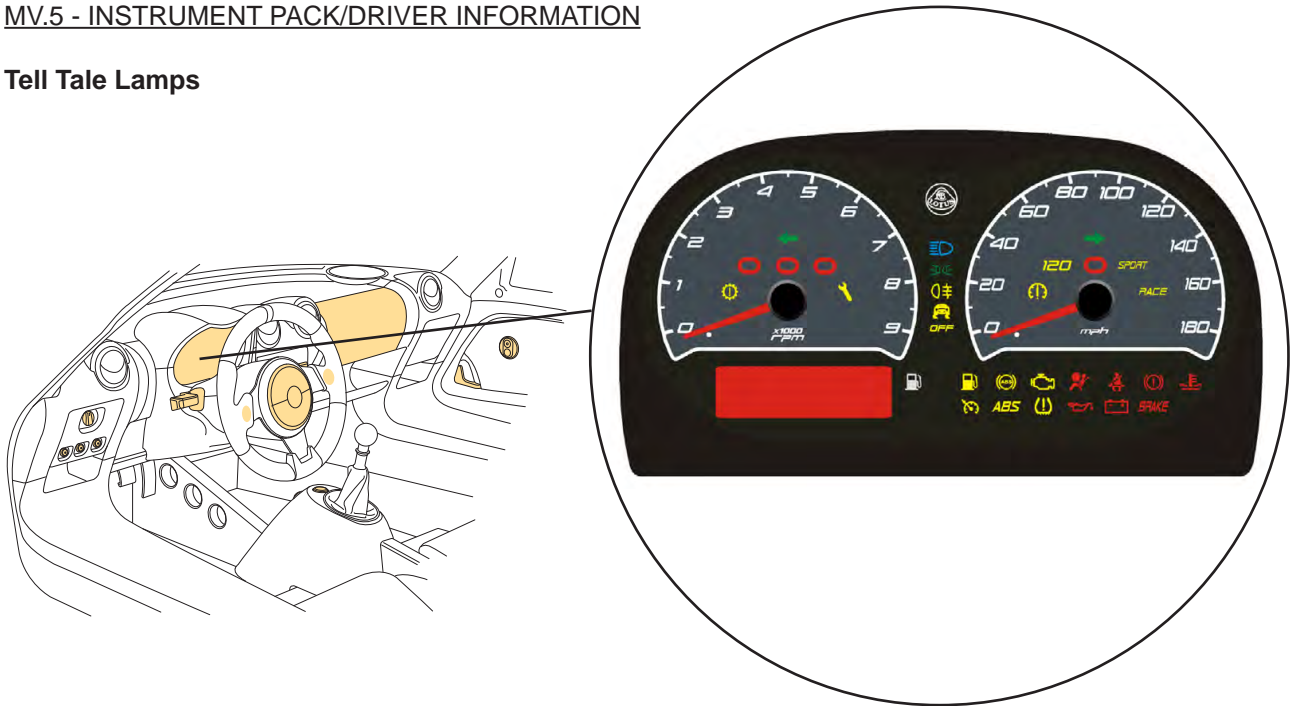

A block of tell tale lamps is incorporated into the instrument cluster to indicate the operational status of various systems.



**Speedometer**

Displays road speed in either MPH or km/h according to market.



**Tachometer**

Indicates engine speed in revolutions per minute. Three red tell tale lamps in the tachometer illuminate in sequence at high rpm (dependant of gear engaged) to warn that the maximum engine speed is being approached.

The Exige S maximum continuous engine speed is limited to 6600 rpm once normal running temperature is reached. Very short bursts up to 6800 rpm are allowed during maximum acceleration through the lower gears (or 7200 rpm in Sport mode).

A 6400 rpm rev limit is imposed on a cold engine to protect against possible damage. The use of wide throttle openings and/or high rpm before normal running temperature has been reached will result in premature wear and should be avoided.

**NOTICE:** The use of wide throttle openings and/or high rpm before normal running temperature has been reached should be avoided. The engine management system graduates the maximum engine speed for a cold engine, in order to reduce possible damage and wear from a delinquent driving style.

- Do not run the engine continuously at its maximum speed.
- The engine is not protected from over speeding caused by erroneous or premature down changing, the consequences of which could be catastrophic failure not covered by the New Vehicle Warranty.
- Use of maximum engine speed and this tell tale facility should be restricted to occasions when maximum acceleration is required. Overuse will compromise powertrain service life.



## Recalibration of Instrument Display

The speedo and tacho needle 'zero' positions will occur during a three second period following ignition switch on, but if a needle becomes 'stranded' outside of the re-calibration range, following the procedure below.

With the vehicle stationary;

- Remove fuse F38 (manual vehicles) or F20 (automatic vehicles) located in the main fusebox;
- Open driver's door;
- Press and hold trip reset button on column shroud;
- Turn on ignition;
- Turn off ignition and refit fuse.

## Tell Tale Lamps

In order to check that the warning systems are operative, all the tell tale lamps (except the 'security' tell tale; see Vehicle Security Alarm) should light for about six seconds following ignition switch on. If any lamp should fail to light, it is possible that the bulb or warning circuit may be faulty.

If a tell tale light fails to illuminate following ignition switch on, flashes constantly or is permanently lit whilst driving, then this may indicate a fault in the operation of the system concerned.

Do not ignore any illuminated warning lights.

## High RPM Tell Tales

Warns that the maximum engine speed is being approached in the current gear. As maximum rpm is approached the tell tales will light in the following left to right sequence:

- one red light
- two red lights
- three rapidly flashing lights

When exploiting maximum acceleration, gearchange upshifts should be made immediately the three flashing lights appear.

**NOTICE:** Use of maximum engine speed and this tell tale facility should be restricted to occasions when maximum acceleration is required. Overuse will compromise powertrain service life.

## Left/Right Hand Turn Indicators

Illuminates when the turn indicators are operating or hazard lights are turn on. If the indicators stay on or flash fast, check the operation of the indicator lamps immediately.

## Rear Fog Lamp Tell Tale

Illuminates whenever the rear fog lamps are operating (see rear fog lamp switch).

## Side lamp Tell Tale

Illuminates whenever the side lamps are operating, and will remain illuminated when the dip and main beams are activated.

## Main Beam Tell Tale

Illuminates whenever the headlamp main beams are operating.

## 120 Km/h Tell Tale (Market specific)

## Security Alarm Tell Tale

The security tell tale is sited in the speedometer face, and indicates the status of the immobiliser and alarm. For full details of the vehicle security system, refer to sub-section MV.1.



## 'Sport' Mode Tell Tale

Illuminates whenever 'Sport' mode has been selected, refer to sub-section MV.7 for further details.

## 'Race' Mode Tell Tale

Illuminates whenever 'Race' mode has been selected - *applicable to 'Race' pack models only*, refer to sub-section MV.7 for further details.

## Electrical Fault Tell Tale

The Engine Control Module (ECM) is also used to manage various related electrical systems, and is able to detect certain types of fault, which may or may not be apparent to the driver. If such a fault is detected, which has no detrimental effect on exhaust emissions (see MIL tell tale information) this tell tale will light for the first 30 seconds after turning on the ignition.

## Lotus Dynamic Performance Management (Lotus DPM)

Whilst driving the tell tale may flicker amber, indicating that the Lotus DPM has been triggered and electronic intervention is taking place; the tractive limit has been reached and driving style should be modified accordingly. See Service Notes section JM.10 and sub-section MV.7 for further information. If however the warning lamp illuminates constantly, a fault has been detected, and (Lotus DPM) will not be enabled.

## Lotus Dynamic Performance Management (Lotus DPM) 'Off'

This lamp will glow amber if the (Lotus DPM) has been manually switched off, and sub-section MV.7 for further information.

**⚠ WARNING: (Lotus DPM) should always be active when driving on public roads in normal conditions.**

## Low Fuel Level

Will illuminate when only a single segment of the fuel gauge bar graph remains, representing approximately 5 litres the amber tell tale will flash. Refuel at the next opportunity.

## Cruise Control

Illuminates whenever cruise control is in standby mode or enabled.

## Anti-lock Braking System (ABS)

If the lamp remains lit, or comes on whilst driving, a fault in the ABS is indicated. However the vehicle retains conventional servo-assisted braking. Heavy braking, or braking on slippery surfaces may cause one or more wheels to lock and result in reduced steering response and possible loss of control.

The car may continue to be driven with appropriate care and anticipation, but should be checked and repaired at the earliest opportunity. Also refer to Service Notes section JM.10 for further information.

## Malfunction Indicator Lamp (MIL)

The engine Malfunction Indicator Lamp (MIL) is provided to warn the driver that the engine management system has detected a fault which may result in increased noxious emissions from the exhaust. In order to minimise emissions and potential engine damage, various operational limitations may automatically be applied.

- i) If the MIL lights continuously whilst driving, immediately reduce speed and adopt a moderate driving style. Seek Lotus dealer advice without delay and avoid all unnecessary journeys.
- ii) If the MIL flashes, an engine misfire has been detected which is likely to cause overheat damage to the catalytic converter.

Slow down immediately and be prepared to stop.

- If the MIL then stops flashing, and is lit continuously, proceed with caution and seek dealer advice.
- If the MIL continues to flash, stop the vehicle as soon as it is safe to do so, and switch off the engine. Seek Lotus dealer advice.



NOTICE: Continuing to drive the car with a flashing MIL may cause overheat damage to the catalytic converters and surrounding bodywork.

⚠ WARNING: Continuing to drive the car with a flashing MIL may cause an engine bay fire.

## Tyre Pressure Monitoring System

Also referred to as TPMS, for limited markets only. Will indicate when if any tyre pressure fall below 75% of the recommended value.

## Oil Pressure

Illuminates to warn of low oil pressure and should extinguish as soon as the engine is started. If the lamp fails to go out after engine start up, or comes on when the engine is running, stop the engine immediately and do not restart until the cause has been investigated and rectified.

**NOTICE:** Continuing to run the engine with the oil tell tale lit could cause major engine damage or seizure.

⚠ **WARNING: Continuing to run the engine with the oil tell tale lit could result in loss of car control and a crash. You or others could be killed or seriously injured.**

## Airbag

The tell tale will illuminate for approximately 6 seconds following ignition switch on. If the lamp remains lit, or comes on at any other time, a fault in the airbag or pre-tensioned seat belt system is indicated, which should be rectified without delay.

⚠ **WARNING: If the airbag tell tale is lit, the airbags may not inflate correctly in a crash, or may inflate without warning; or the pre-tensioning seat belts may not perform correctly. To reduce potential injury to driver and passenger, the airbag system should be repaired as soon as possible.**

## Battery Charging

If it lights any time when the engine is running, the battery is not being charged, which may be due to a broken auxiliary drive belt, or an electrical fault. Stop the car as soon as safely possible and turn off the engine. The auxiliary belt also drives the engine water pump, without which function the engine will overheat very quickly.

⚠ **WARNING: Do not, under any circumstances, allow the battery to become completely discharged by continuing to drive, as this may result in the vehicle being stranded in a dangerous position.**

## Seat Belt

The lamp will flash for about 6 seconds following ignition switch on as a reminder that both driver and passenger should always wear their seat belts, no matter how short the journey. The lamp will continue to flash if the driver's seat belt is not fastened accompanied by a warning buzzer if the vehicle speed exceeds 13mph (20kph).

The tell tale and buzzer will remain active until the driver's seat belt has been fastened. Variations may apply dependent on local market legislation.

## Brakes

This tell tale will illuminate with the ignition switched on whenever the parking brake is applied. Each time the parking brake is released, check that the tell tale is extinguished.

With the parking brake released, if the tell tale should light at any time after the check period, stop the car immediately, as the circuit has detected a dangerously low level of brake fluid in the master cylinder reservoir. The car should not be driven until the fault has been identified and rectified.

⚠ **WARNING: If the tell tale remains lit when the parking brake has been released, the footbrake may not be working properly. Stop the car immediately if it is safe so to do, and do not continue until the fault has been rectified. Continuing to drive could cause a crash and result in death or serious injury.**



**L Coolant Temperature**

The initial tell tale illumination colour is blue until the engine coolant reaches normal operating temperature at which time the tell tale will extinguish. The tell tale will then illuminate red in colour if coolant temperatures exceeds 113°C in order to prompt closer monitoring of high temperatures. Also see Service Notes section KR for further information on engine cooling.

**Transmission Malfunction Indicator  (Automatic Exige S Only)**

A bulb check will light the lamp for about 3 seconds following ignition switch on.

**Warning Modes**

*Oil Temperature:* The Transmission Malfunction Indicator lamp will flash if the temperature of the transmission oil becomes too high and the vehicle will default to a limited power mode, reduce vehicle road speed until the lamp extinguishes.

*Transmission Fault:* The Transmission Malfunction Indicator lamp will illuminate continuously if a fault is detected within the transmission or an associated component, reduce vehicle road speed immediately and adopt a moderate driving style.

Note: Even if the Transmission Malfunction Indicator lamp extinguishes, proceed with caution and seek dealer advice without delay and avoid all unnecessary journeys.

*Emissions Fault:* If a fault is detected within a transmission component which could affect the vehicle’s emissions, then the engine Malfunction Indicator Lamp (MIL) will also illuminate continuously in conjunction with the Transmission Malfunction Indicator lamp.

Refer to MIL light tell-tale information regarding the driving style that should be adopted if the MIL lamp is illuminated or flashing.

NOTICE: Continuing to drive with an illuminated Transmission Malfunction Indicator lamp may cause damage to the transmission.

Note: Depending upon the cause, frequency and duration of the tell tale illumination it may be necessary to renew the transmission fluid even if all monitored transmission components are operating correctly.

**LCD DISPLAY (Manual Vehicles)**

Refer to page 25 for specific information on automatic vehicles

A liquid crystal display (LCD) panel is located within the instrument panel in order to display fuel level, coolant temperature, total mileage, trip functions and alternative speed. The panel is blank until the ignition is switched on.

**Auto Shutdown**

After 20 minutes of inactivity and with the key in the ignition off position (see page 26), the (LCD) display will automatically power itself down. The display will power up when the ignition is turned to the on position or if certain driver operated controls are activated such as the side lamps (The alarm tell tale will still continue to illuminate even if the pack has powered down).

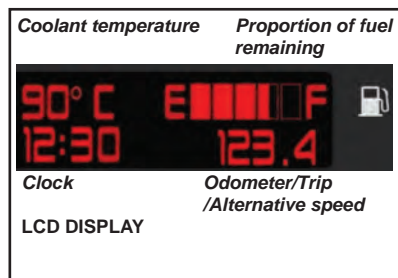

**Fuel Contents Display**

An indication of the level of fuel in the tank is displayed in the form of a bar graph to the right hand top of the (LCD) panel. When completely full (approximately 43.5 litres {9.6 U.K. gal}), the display will display six red segments. As the fuel level falls, the segments will gradually disappear from the right hand side of the display. The remaining segments represent an approximation of the remaining fuel.

NOTICE: Do not allow the tank to run completely dry, as this could damage the catalytic converter and fuel pump. Any such consequence would not be covered by the New Vehicle Warranty.



## Coolant Temperature Display

The engine coolant temperature is not displayed until it reaches 70°C. At that time the coolant temperature tell tale (blue in colour during engine warm up) will extinguish and the temperature display will appear at the upper left hand of the (LCD).

If the displayed temperature exceeds 113°C, the coolant temperature tell tale will illuminate red in colour in order to prompt closer monitoring of high temperatures and will continue to display coolant temperature up to 120°C.

**Note:** The running temperature will fluctuate a certain amount as the operating conditions change, and during periods of idling or in heavy traffic, the temperature may rise to over 100°C, with the cooling fans switching on at half speed at approximately 98°C and at full speed at approximately 103°C.

As the pressurised cooling system has a boiling point of over 120°C, only if the temperature approaches this level need there be any cause for concern. If this should occur, allow the engine to idle for a few minutes whilst monitoring the temperature, and if it continues to rise, switch off and seek qualified assistance.

**NOTICE:** After a heavy snowfall, ensure that the radiator cooling outlet grilles in the front body are cleared of snow before driving the car, or overheating may occur.

## Odometer

An odometer (total distance recorder) reading is displayed at the bottom right hand corner of the panel, and is calibrated in the same units (miles or kilometres) as is the speedometer.

## Trip Distance/Speed Display/Odometer

Note: The display will always default to the alternative speed display option when the ignition is initially turned on regardless of the last option selected during the previous drive cycle. The bottom right portion of the LCD panel may be cycled through the following displays:

- Trip distance.
- Digital road speed in alternative units to those indicated by the analogue instrument (either mph or km/h).
- Odometer.

To cycle, one at a time, through these three displays, briefly press the instrument panel illumination button on the right hand side of the steering column shroud,

**Note:** This button also adjusts the brightness of the instrument and heater/air conditioning and panel illumination if held pressed when road speed is selected.

Trip distance: Units displayed are common to the analogue speedometer scale, and range from 000.0 to 999.9.

To reset to zero; when the trip function is displayed, press the button on the column shroud for longer than 1 second.

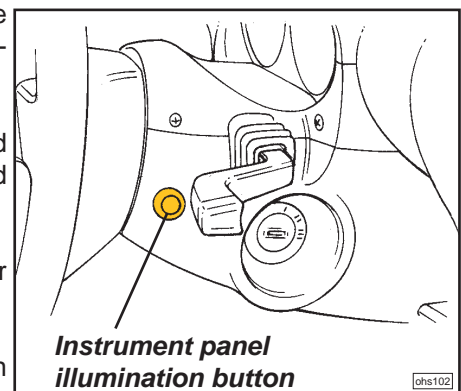

## Clock

Time clock setting: To adjust the 24 hour time clock cycle the instrument panel illumination button until the Odometer reading is displayed\*. Press the panel illumination button on the column shroud again for longer than 1 second. The hour display will then flash.

- Repeated brief presses of the button will increment the hour figure. Pressing the button for longer than 1 second will store the hour setting and start the minute display flashing.
- Further brief button presses will increment the minute figure.
- When the correct time is displayed, press the button for longer than 1 second to store the setting and start the clock.

\* Note: For automatic vehicles the clock needs to be displayed to adjust settings.





**LCD Display for Automatic Vehicles**

The engine coolant temperature and time clock display are incorporated into the driver controllable display options on the bottom right hand of the LCD screen.

For automatic vehicles the shift mode and gear selection (when in manual mode) are displayed on the left hand side of the screen.

Initially the clock is displayed when the key is inserted into the ignition; this is replaced by the alternative speed setting once the key is turned to position II.

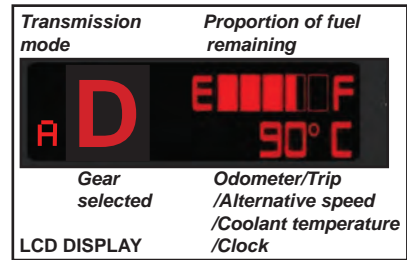

Depressing the panel illumination button for a period of less than 1 second will cycle through the various LCD panel display options. Refer to service note section FB.2 - Automatic Transmission for further information.

**Instrument Panel Illumination Button**

*Removal:*

- 1.Remove the upper and lower steering column shrouds, refer to service note section VE.4 for further information.
- 2.Disconnect the main harness multiplug connector from the instrument panel illumination button lead.
- 3.Release the switch retaining nut from the rear of the lower steering column shroud panel, allowing the switch/harness to be withdrawn from the front of the panel.

*Refitment:*

Is the reverse of removal.

**Instrument Pack Serviceability and Applications**

Instrument packs are supplied as either MPH or KPH, Manual or Automatic part numbers with the unit of speed printed onto its face. It is a sealed non-serviceable component pre-installed with non-erasable base software to make them compatible with any Exige model by VIN range and options fitted.

**Instrument pack removal/renewal**

If it is necessary to remove or renew an instrument pack then it is highly recommended that before removing the existing unit that you note down its variant code and current mileage, as this information will have to be downloaded onto the replacement pack using the Lotus TechCentre vehicle configuration screens.

Note: Even if the instrument pack is only being removed to gain access to other ancillary components it is still advisable to note its variant code as a precautionary measure.

Note: Although it is possible to manually enter the variant coding from the option screens available there is a risk of making an error if this option is selected which may affect the display and or functionality of the instrument pack.

If the variant coding has not been recorded or if the instrument pack will not communicate with Lotus TechCentre then it is advised to contact Lotus Cars Technical Publication Department stating the full vehicle VIN requesting the variant code information.

Although vehicle mileage can be reset using Lotus TechCentre, to prevent potential abuse a limitation to this function has been imposed, once the mileage/kilometre display on the odometer exceeds 50 miles or 75 kilometres the odometer reading can no longer be altered.



Instrument cluster configuration screen as viewed using Lotus TechCentre

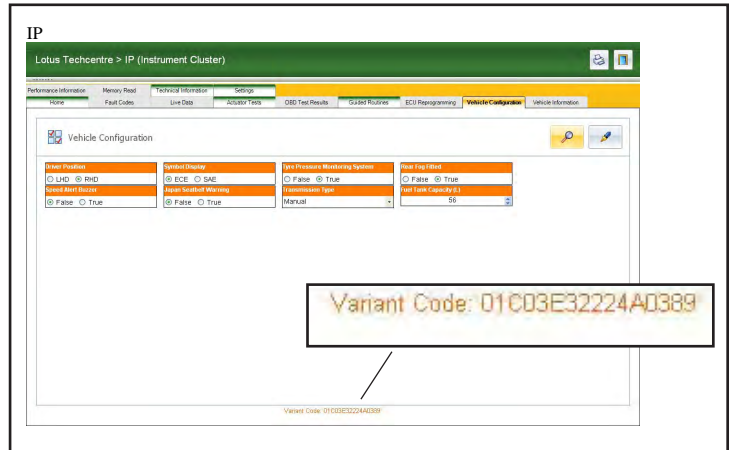

**INSTRUMENT PACK REMOVAL**  
(Steering wheel removed for clarity)

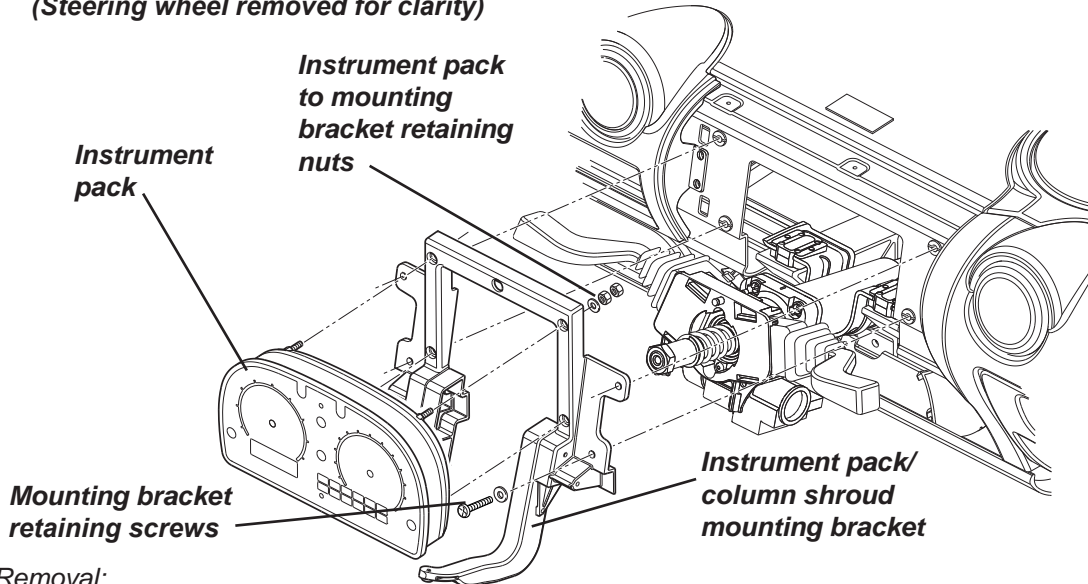

**Removal:**

- Carefully pull the instrument pack cowling/shroud away from the dashboard to release the retention spring clips (4) from their apertures in the dash panel, refer to service note section VE.5 for further information.
- Remove the No. 8 x 3/4" self tapping screws and M6 washers (4) securing the instrument pack/column shroud mounting bracket to the dashboard.
- Carefully withdraw the instrument pack and mounting bracket away from the dashboard area, disconnect the main harness multiplug connector from the rear of the instrument pack.
- The assembly can now be fully withdrawn from the vehicle and the instrument pack detached from the bracket by releasing the M4 nuts and washers (4) securing the instrument pack to the mounting bracket.

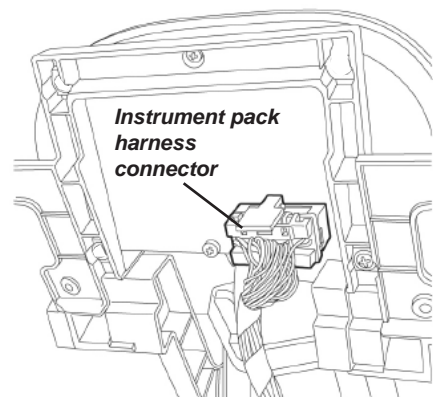

Note: If the steering wheel is still in situ the instrument pack and mounting bracket will have to be lifted up and manoeuvred around the steering wheel to withdraw it from the vehicle.

**Refitment:**

Is the reverse of removal, except that it may be necessary to reset mileage and variant code if the instrument pack has been renewed, please see previous page for details.



MV.6 - SWITCHES & INSTRUMENTS

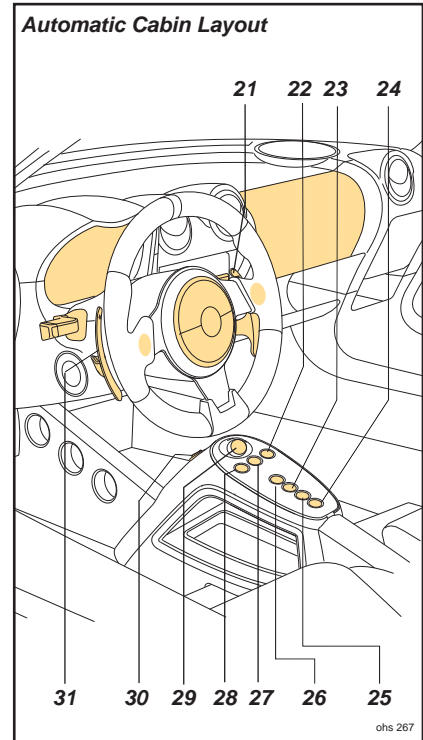
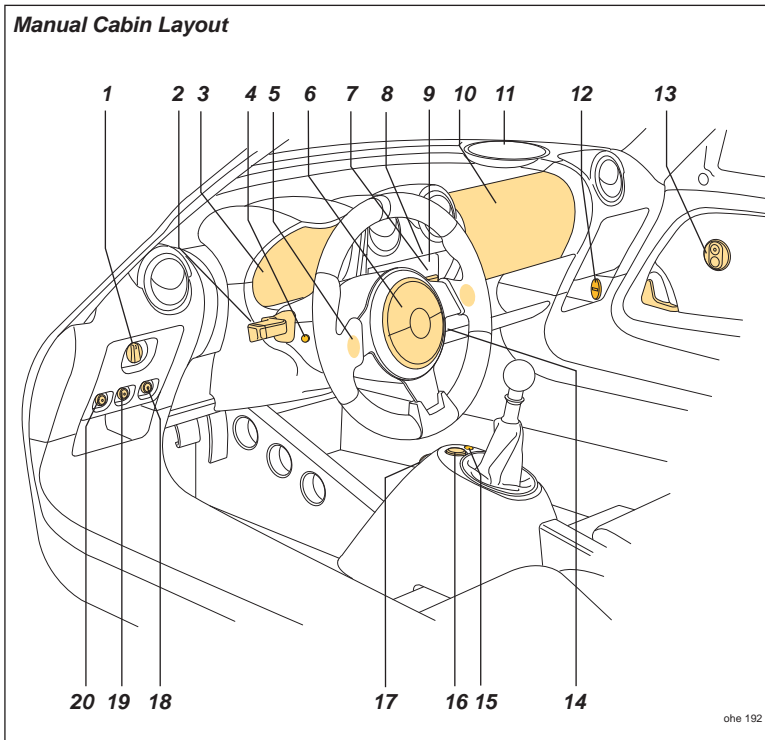

1. Lotus DPM (Dynamic Performance Management) mode switch
2. Headlamp Dipswitch/Flasher/Turn/Indicators/Cruise control column switch
3. Instrument panel
4. Engine protection valve override switch (where fitted)
5. Horn switch
6. Driver's airbag - Refer to service notes section WC.9 for further information
7. Wash/wipe control column switch
8. I.C.E (In Car Entertainment) system
9. HVAC (Heating, Ventilation & Air Condition) controls - Refer to service notes section PK.2 for further information
10. Passenger Air Bag - Refer to service notes section WC.11 for further information
11. Speaker
12. Auxiliary power socket - 5 Volt DC USB
13. Door window switch
14. Instrument panel illumination (opposite side to item 4)
15. Heated rear window switch - Refer to service notes section PK.2 for further information
16. Hazard warning light switch
17. Interior CDL (Central Door Locking) switch
18. Rear fog lamp switch
19. Headlamp switch
20. Sidelamp switch
21. 'Up' shift paddle
22. RH heated seat switch
23. R - Reverse selector button
24. D - Drive selector button
25. N - Neutral selector button
26. P - Park selector button
27. Heated rear window switch
28. LH heated seat switch
29. Hazard warning light switch
30. Interior CDL (Central Door Locking) switch
31. 'Down' shift paddle



Lotus DPM (Dynamic Performance Management) & Lighting Switches

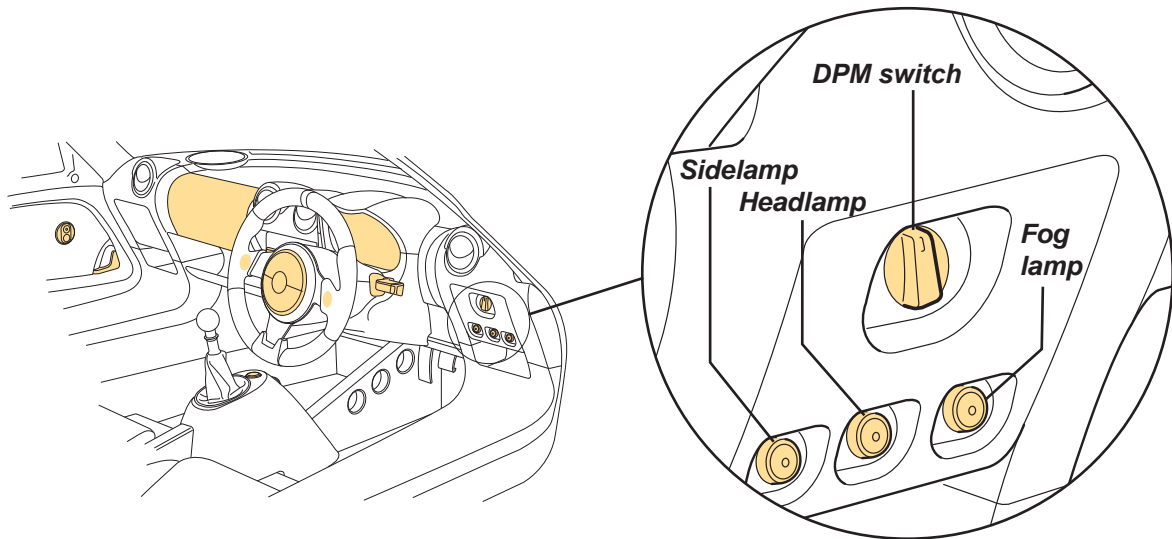

Lighting functions are controlled by a horizontal row of three push button switches mounted in a switch panel housing trim within the fascia, outboard of the steering column. Each switch is pressed once to switch on, and pressed a second time to switch off. A symbol is positioned on the head of each switch to indicate its function.

The light switches are illuminated with the ignition on and become brighter when pressed.

*Sidelamp switch*

Positioned outermost, this switch functions with or without ignition, and switches on the sidelamps. A tell tale in the switch button lights up green to indicate when the circuit is active. Note that the headlamps must be off before the sidelamps can be switched off

*Headlamp Switch*

The centre switch functions with or without ignition, and switches on the headlamps together with the sidelamps if not already selected by the sidelamps switch. The steering column lever switch (see later) is used to select main beam or dip. Pressing the switch a second time will switch off the headlamps, but leave on the sidelamps.

*Rear Fog Lamp Switch - If Fitted*

The innermost switch controls the two rear fog lamps (where fitted), and may be selected only after first switching on the ignition, and then the headlamps. A tell tale in the switch button lights up amber to indicate when the circuit is active.

Note that the switch will default 'off' whenever the headlamps or ignition are switched off, requiring reselection if lamp activation is again desired.

In some territories, rear fog lamps may be used legally only in conditions of 'seriously reduced visibility'.

Be aware that indiscriminate or forgetful use of the rear fog lamps can cause distraction and discomfort to following traffic.

*Lotus DPM (Dynamic Performance Management) switch*

The Lotus DPM switch has 3 or 4 driver selectable modes which are controlled from the Lotus DPM switch positioned outboard of the steering column.

*Daytime Running Lamps (DRL)*

When the engine is started, the front sidelamps will automatically be activated as daytime running lamps, with the front sidelamps operating with an increased intensity. When the ignition is turned off, the DRLs will switch off automatically unless manually selected.

If the sidelamp switch is activated whilst the engine is running the front DRLs will revert to their sidelamp functionality and operate with a reduced intensity.

#### *Lights On' Warning*

A 'lights on' reminder buzzer will sound if the lights are on when the ignition is switched off and the driver's door is opened. The buzzer is located within the instrument pack and cannot be replaced without renewing the complete pack assembly.

### **Light Switches**

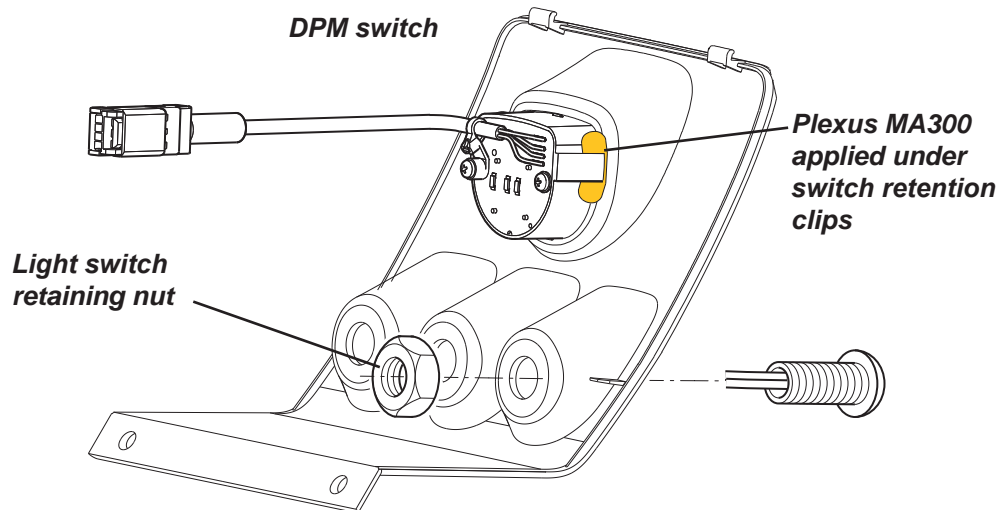

#### *Removal:*

Remove the switch panel housing, see service notes section VE.3 for further information.

The light switches can be removed from the panel housing trim by releasing the relevant switch retaining nut from the rear of the panel, allowing the switch/harness to be withdrawn from the front.

#### *Refitment:*

Is the reversal of removal.

### **Lotus DPM (Dynamic Performance Management) Switch**

The DPM switch is retained to the panel with the aid of a small quantity of Plexus MA300 adhesive which is applied under the switches integral retention clips pushing them outwards so forcing the switch tight against the panel.

#### *Removal:*

To remove the separate the switch from the panel will require the plexus to be carefully cut away from the retention clips before it can be withdrawn.

#### *Refitment:*

Is the reverse of removal but requires a small quantity of Plexus MA 300 adhesive (2.5ML) to be applied under each retaining lug once the switch has been fitted in the panel housing.

Headlamp Dipswitch/Flasher/Turn Indicators

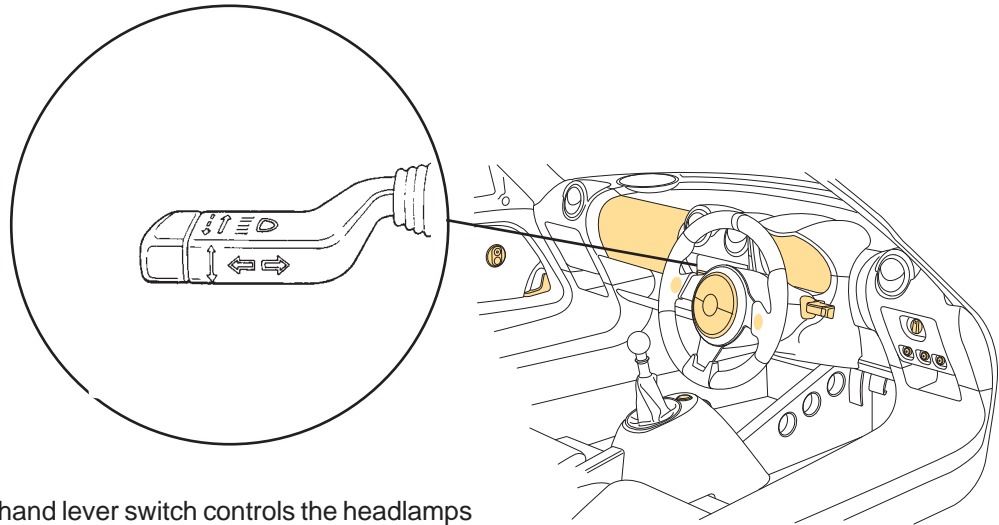

The steering column left hand lever switch controls the headlamps main beam/dip, headlamp flash and turn indicators.

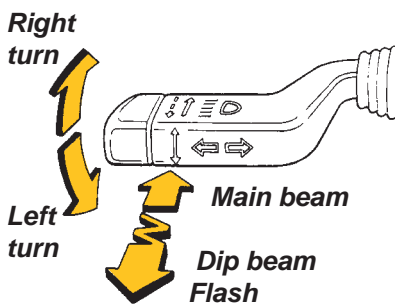

**Headlamp Dipswitch:** To switch on the headlamps, press the headlamp switch in the fascia outboard of the steering column, (see previous pages).

The left hand lever switch is then used to select main or dip beam.

Main beam is obtained with the lever furthest forward, away from the steering wheel, and dip beam with the lever moved back towards the wheel. The main beam tell tale lamp in the instrument panel lights when main beam is operating.

*Note:* When main beam is selected, the dip beam lamps remain lit.

**Headlamp Flasher:** The headlamp flasher is operative at all times. If the lever is pulled towards the steering wheel against spring pressure, the headlamp main beams will light.

**Turn Indicators:** The turn indicators operate only with the ignition switched on. Move the lever down to indicate a left hand turn, and up for a right hand turn. The switch will be cancelled when the steering wheel is returned to the straight ahead position. For convenience, when signalling a lane change, lightly pressing the switch up or down will allow its return under spring action.

**Switch removal (Cruise control and RH wash/wipe switch similar)**

**Removal:**

- 1.Remove the upper and lower steering column shrouds, refer to service note section VE.4 for further information.
- 2.Disconnect the main harness multiplug connector from the column switch connector.
- 3.Squeeze the upper and lower switch retaining pawls and slide the switch out of the column carrier.

**Refitment:**

Is the reversal of removal.

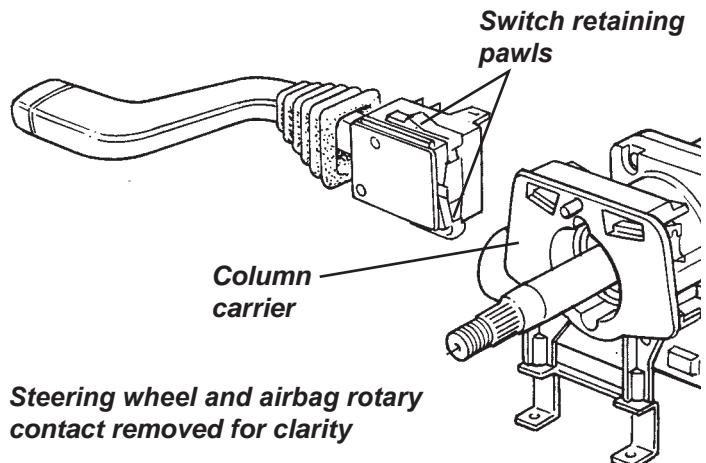



**Windscreen Wiper/Washer**

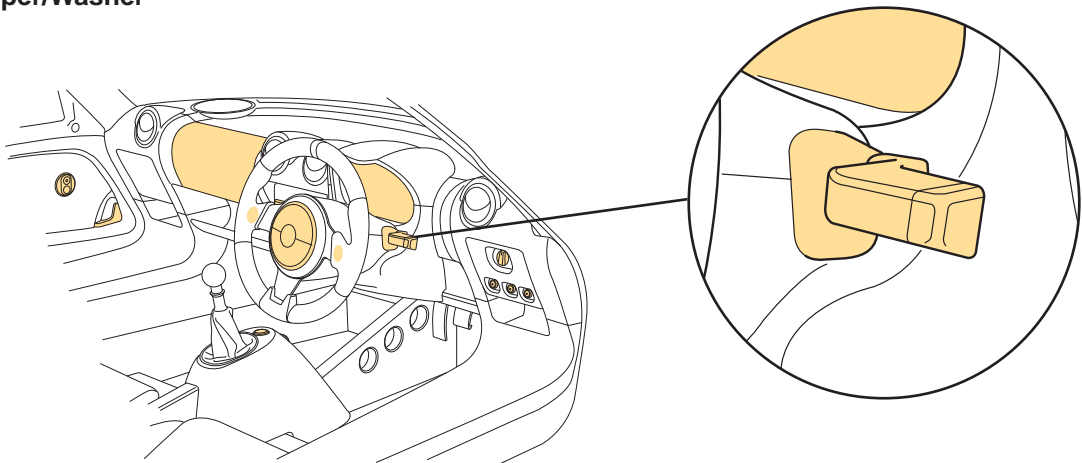

The steering column right hand lever switch controls the windscreen wiper and washer, and is operative only with the ignition switched on.

Never use the wiper on a dry screen.

*Windscreen Wiper:* The wiper is controlled by the up/down position of the lever switch, which operates as follows:

- Moved fully down, the wiper is switched off.
- Move up to the first position for intermittent wipe. The wiper will make one sweep about every five seconds.
- Select the next position for normal wiper operation.
- Move fully upwards for quick wipe, to be used only in heavy rain.

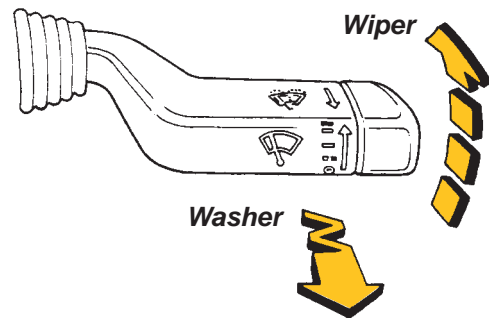

*Windscreen Washer:* Two windscreen washer jets are provided, one each side of the wiper spindle. Pulling the control lever towards the steering wheel will operate both the washer pump and the wiper. When the switch is released, the wiper will continue for a further four sweeps.

*Switch Removal:*

See Headlamp Dipswitch/Flasher/Turn Indicator information on removal and refit procedure.



## Cruise Control

Cruise control is available as an optional fitment with the control buttons added to the headlamp dip/flasher/turn Indicator switch.

**Caution:** Cruise control should be used only when conditions are favourable; on straight, dry, open roads with light traffic.

The cruise control system is incorporated into the engine ECU programme and selected as an available option within the variant coding options using Lotus TechCentre

*To enable cruise control:* The system will always default to 'off' whenever the ignition is turned off. To enable cruise control, turn on the ignition, and press the on/off/cancel switch; the tell tale in the instrument panel will light to confirm that the system is enabled (although no speed has yet been set). Alternatively, this operation may be combined with that for activation, by pressing the on button followed by the set button.

### To activate cruise control

With the system enabled, drive the car to the desired cruising speed and press once the 'I' end of the rocker switch with the raised pip. The accelerator may now be released, but the set speed will be maintained (road gradient and winds permitting). The accelerator may be used to increase speed temporarily without affecting the setting.

Note: The system cannot be activated below 28 mph (45 km/h) or above 130 mph (210 km/h), or in first or second gear for either manual or automatic vehicles.

### CRUISE CONTROLS (if fitted)

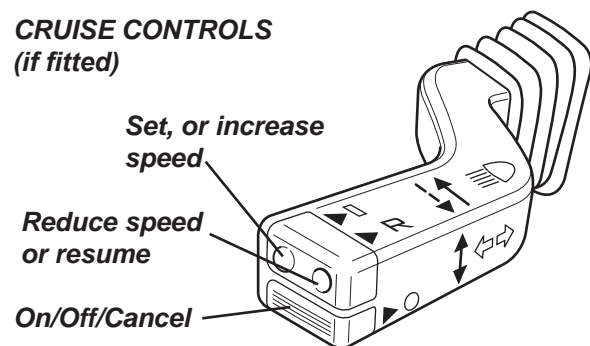

### Changing the cruise setting

Whilst cruise is active, the speed setting can be adjusted by:

- Manually accelerating or braking to the desired new speed, and then press the 'I' switch once to reset.
- Holding down the 'I' or 'R' buttons to accelerate or slow the car to the desired new speed. On release of the button, that speed is set.
- Repeated short presses of the 'I' or 'R' buttons to increase or decrease the setting by increments of 1 km/h.

### Deactivation of cruise control

- Cruise control will automatically deactivate by any of the following actions:
- Depression of the brake or clutch pedal.
- Automatic transmission selects either second or first gear (in either automatic or manual sequential gear selection mode).
- The on/off/cancel button is pressed once.

In any of these cases, normal manual speed control will be restored, but the system will remain enabled and the cruise control tell tale will remain illuminated.

#### *Resuming a set speed:*

With the accelerator pedal released press the 'R' button once and the vehicle will automatically accelerate or decelerate to the last activated set speed.

Note: The resume function should be used only if you want to return to, and are aware of, the set speed.

#### *Set speed cancellation*

The set speed will be reset to zero when you turn cruise control off (from the enabled state) or if the ignition is switched off.

### To disable cruise control

Press the 'O' button once from the enabled state or twice from the active state and the cruise control tell tale will extinguish.

#### *Switch Removal:*

See Headlamp Dipswitch/Flasher/Turn Indicator information on removal and refit procedure.





**Auxiliary Power Sockets & Courtesy Lamp**

*12 Volt DC*

An auxiliary power socket is fitted in the centre trim shroud on the rear bulkhead. The socket is operative at all times, and is provided with a protective hinged flap.

The socket allows the use of a standard cigarette lighter element or other electrical accessories requiring this type of fitting. The maximum current draw should not exceed 15 amps.

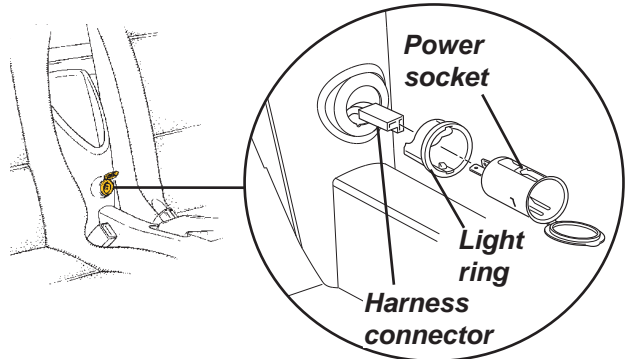

*Removal:*

The socket can be removed by carefully withdrawing it from the trim shroud, if the socket will not pull away without potentially damaging the shroud then release the No. 6 x 3/8" screw securing the Stowage Pocket to trim shroud so that it can be pushed out instead,

*5 Volt DC (If fitted)*

An additional USB charging port is fitted in the passenger storage pocket and is active with the key in the ignition.

The socket allows electrical accessories to be charged or powered that can use a USB type adaptor lead. The maximum current draw should not exceed 1 amp.

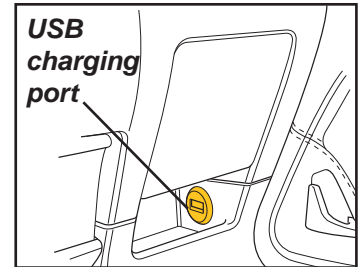

**Courtesy lamp**

The courtesy lamp is sited centrally in the rear bulkhead trim. Its 12V 5W bulb receives power from fuse F37 in the front fuse box and has 4 illumination modes which are controlled by rotating the lamp lens within its housing.

Mode: **Instant permanent illumination**

Lens position **Central**

Contacts within the lamp unit illuminate the bulb instantly to full power (with or without ignition) by completing the circuit directly to earth.

Mode: **Courtesy mode illumination or extinguish by door opening/closing**

Lens position **Fully downwards**

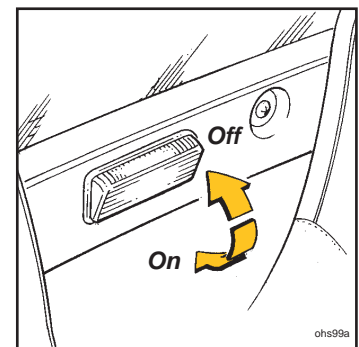

Contacts within the lamp unit are switched to complete the circuit through either the driver or passenger door pin switches. When either door is opened the contacts in the pin switch close, completing the circuit and illuminating the lamp instantly to full power.

Mode: **Illumination by alarm de-activation or ignition switch off driver/passenger door closed**

Lens position **Fully downwards**

The courtesy light will fade on and remain on for 2 - minutes after the alarm or ignition is switched off. A wiring splice in the harness between the lamp and door pin switch is connected to pin terminal 11 of the alarm immobiliser unit which is located under the instrument panel.

Alarm activation or ignition switch off signals a MOFSET (Metal-Oxide Semiconductor Field-Effect Transistor) within the immobiliser unit which allows the lamp to gradually earth through the immobiliser increasing illumination from 0-100% power over a 2 - minute time period at a power rate increase of 2.3 second intervals remaining on for 2 - minutes. Once the 2 - minute timer has expired the courtesy light will fade off at the same rate as illumination.



If the ignition is turned on or the alarm is armed within 2 minutes of courtesy light activation, the timer is automatically cancelled and the light faded off.

Mode: **Permanently off** Lens position **Lens Fully upwards**  
Contacts within the lamp unit are switched open circuit

*Lamp removal;*

1. Carefully ease the assembly out of the rear bulkhead trim.
2. Disconnect main harness connector from terminals.
3. Twist bulb holder and withdraw from lamp housing to gain access to the bulb.

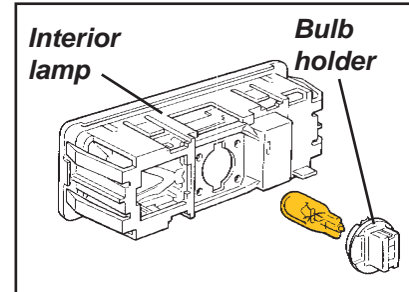

*Refitment;*

Is the reverse procedure to removal.

**Gear selector switch panel/Heated Rear Window/Seat switch panel & hazard warning light switch**

A single piece PRND switch panel, heated rear window/seats and hazard warning light switch are all fitted into the console switch panel.

To gain access to these switches the console switch panel must be removed from the centre console assembly.

*Removal:*

1. From underneath the switch panel, pull out the rubber console closure panel away from the console centre aperture to gain access to the switch panel fixings and harness connections.
2. Release the forward M4 x 25 cap head screw (2) and washers (4) and rear M4 x 16 cap head screw (2) and washers (2) securing the switch panel assembly to the centre console.

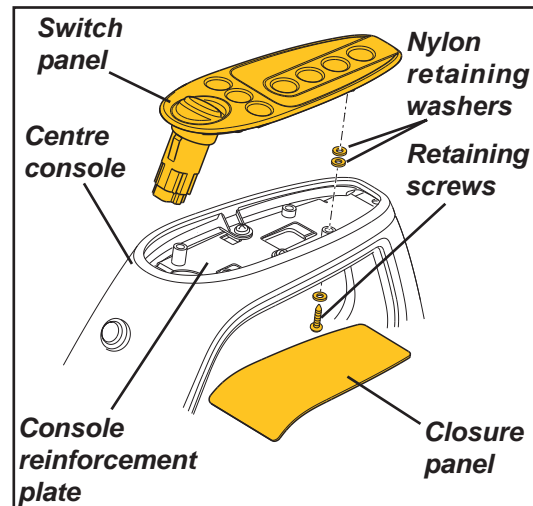

Note: It is not necessary to fully remove the fixing screws from the centre console, 2 Nylon washers are fitted to the threads of each of the four fixing screws above the console reinforcement plate, these ensure that there is sufficient space between the underside of the switches and the console reinforcement plate as well as retaining the fixing screws in place.

3. Carefully lift the panel assembly from centre console and unplug the main harness connectors from the gear selector, heated rear window and hazard warning light switches.
4. Release the Screw, M3 x 8, flg. pozi. hd. self tapping screws and shake-proof washers (8) securing the gear selector and heated rear window switch to the underside of the console panel.
5. Depress the integral retaining clips securing the hazard switch and withdraw it from the panel.

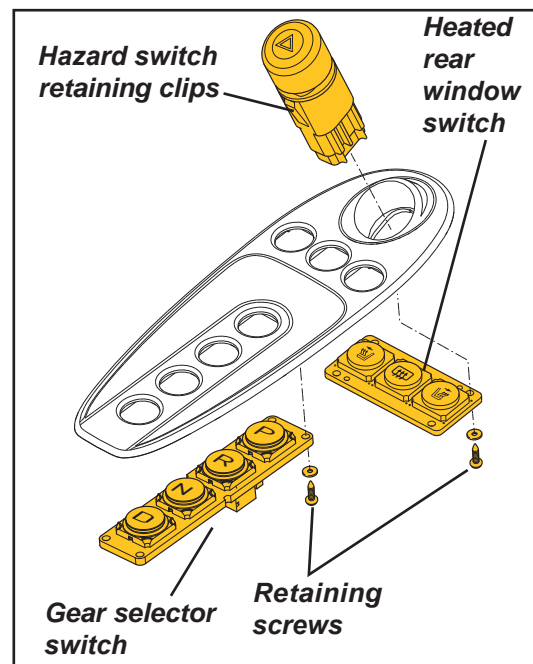

*Refitment:*

Is the reverse procedure to removal.



**Paddle Shift Mechanism Assembly**

Supplied as single assembly comprising of LH '-' down-shift, RH '+' up-shift paddle and switches fitted onto a mounting bracket.

The mounting bracket is fixed onto the steering column switch carrier and ignition lock barrel housing.

*Removal:*

*Preparation:* Remove the drivers airbag module, steering wheel and steering boss from the column but ensure the rotary connector remains in place at this time, refer to service notes section WC.9 and HK.2 for further information.

1. Release the M4 x 12 pan pozi screw (1) securing the lower bracket to the lock barrel housing and the No 10 x 1/2 flg pozi self tapping screws (2) securing the bracket to the switch carrier lower mounting points
2. Release the No 6 x 1/2 pozi self tapping screws (2) securing the bracket to the switch carrier upper mounting points
3. Unplug the main harness connector from the paddle shift assembly and withdraw the assembly and rotary connector from the steering column.

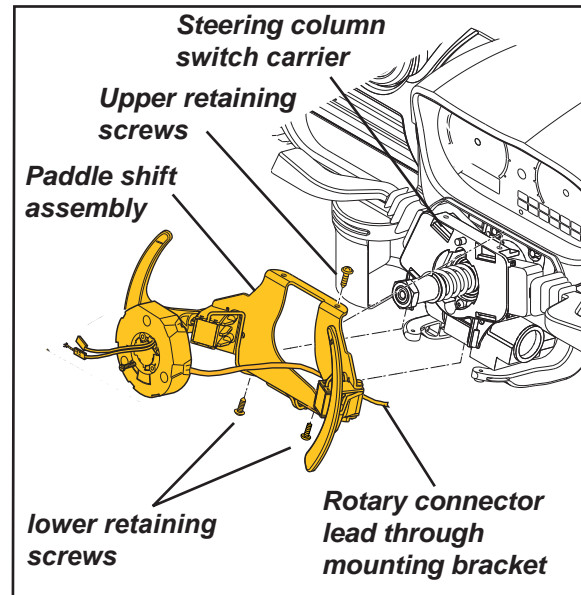

*Refitment:*

Is the reverse procedure of removal, ensure the yellow coloured rotary connector lead is placed through the aperture in the paddle shift bracket before attaching back onto the steering column. Ensure the paddle shift wiring leads do not foul against the rotary connector or inner steering column.

Except: If fitting a service replacement upper steering column assembly it will necessary to use a 2 mm drill bit to produce mounting holes in the switch carrier to accomodate the paddle shift assemblies upper mounting points.

**Horn**

The horn, which functions at all times, is operated by a button embossed with a bugle symbol in each of the steering wheel horizontal spokes. Power to the horn buttons is fed through the airbag clock spring/rotary connector assembly, supplied via a relay located in the main fuse box. The horn buttons are integral to the steering wheel and are non-serviceable, requiring the renewal of the steering wheel if faulty.

Depressing either of the two horn buttons earths out the circuit, switching the contacts in relay and activating the horn.

The horn is secured by a mounting strap to the RH inner crash structure.

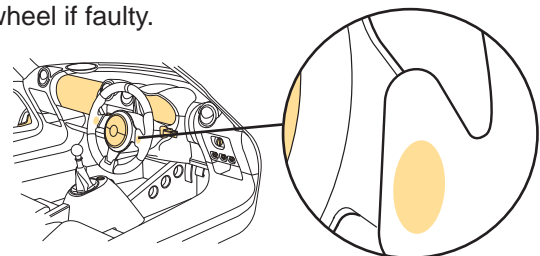

*Horn replacement:*

1. Remove the front clamshell centre intake grille - see Service Notes Section BT.16 for further information.
2. Disconnect the main harness electrical connector from the horn terminal and release and remove the M10 nut securing the horn to it crash structure mounting strap
3. The horn can now be withdrawn from the vehicle.

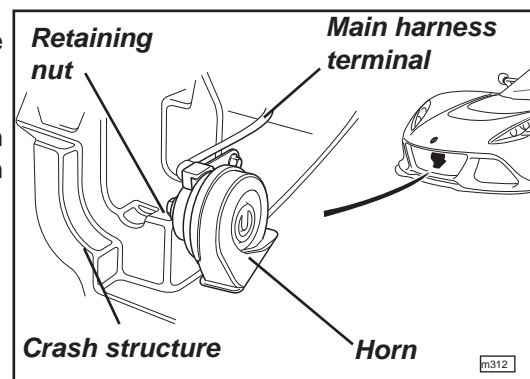

*Refitment:*

Is the reverse of removal.



MV.7 - LOTUS DPM (DYNAMIC PERFORMANCE MANAGEMENT) OPTIONS

Manual vehicles/'latched' switch (see page 42 for automatic vehicles or 'momentary' type switch.

3 Mode Lotus DPM Switch

The standard Lotus DPM (Dynamic Performance Management) system has 3 driver selectable modes which are controlled from the Lotus DPM switch positioned outboard of the steering column above the light switches.

Note: Lotus DPM 'Off' mode can only be selected whilst the engine is running, but can be activated either whilst the vehicle is being driven or is stationary.

⚠ WARNING: Be aware that selecting Sport Mode and/or Lotus DPM 'Off' will alter the handling characteristics of the car. Drivers should exercise caution until familiarity has been gained in a controlled safe environment.

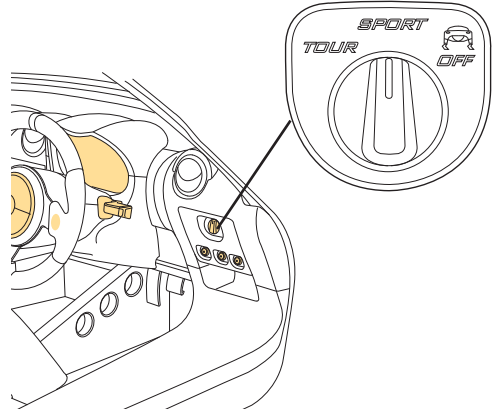

Lotus DPM Mode Settings

- TOUR** 1.Lotus DPM fully activated (see Service Notes Section JM.10 for further details).
- 2.Exhaust active valve will only open at high throttle/RPM applications (see Service Notes Section EM.12 for further details).
- 3.Maximum continuous engine speed restricted to 6600rpm.

- SPORT** 1.Reduction in Lotus DPM settings allowing increased power induced wheel slippage thresholds and no throttle reduction on understeer.
- 2.Exhaust active valve now open whilst engine idling, closes at low engine speeds and reopens from medium throttle applications/engine speeds.
- 3.Maximum continuous engine speed increased to 7000rpm.

- OFF** 1.Lotus DPM de-activated.
- 2.Exhaust active valve is permanently open regardless of throttle position.
- 3.Engine idle speed increased to 900rpm, maximum continuous engine speed increased to 7000rpm.

Lotus DPM 'Off'

Mode Selection

'Sport' Mode

Rotate the switch clockwise from the 'Tour' setting, the amber 'SPORT' tell tale in the instrument panel will be illuminated.

The vehicle will immediately engage 'Sports' Mode.

Note: if selected whilst driving, this may cause the exhaust active valve to open without increased throttle pedal depression as well a reduction in the Lotus DPM system functionality.

The Lotus DPM tell tale will flash when electronic intervention is taking place indicating that the systems tractive limit has been reached.

To Switch Off 'Sport' Mode

Rotate the switch back to the 'Tour' position.

Note: 'Sport' mode can be activated even if the engine is not running, therefore if the engine is turned off whilst in 'Sport' mode the vehicle will revert back to 'Sport' Mode when the engine is restarted.



### *Lotus DPM 'Off' Mode*

Rotate the switch fully clockwise from either the 'Tour' or 'Sport' setting. Hold the switch for at least one second in the Lotus DPM 'off' position and then release, the switch will return to the 'Sport' position.

The Lotus DPM 'Off' lamp within the instrument panel will now be illuminated. See sub-section MV.5 for further details.

Note: if selected whilst driving, the vehicle will immediately engage Lotus DPM 'Off' Mode, the exhaust active valve will open regardless of the throttle pedal position and the Lotus DPM system will be immediately disabled.

### To Cancel Lotus DPM 'Off' Mode

Rotate the switch back to the 'Tour' setting.

Note: If the engine is turned off whilst in Lotus DPM 'Off' mode the vehicle will revert to 'Sport' mode when the engine is restarted.

⚠ WARNING: (Lotus DPM) should always be active when driving on public roads in normal conditions.

### 'Sport' Mode from Lotus DPM 'Off' Mode

Turn the switch from its 'Sport' to 'Tour' position then return it back to the 'Sport' mode position setting.



4 Mode Lotus DPM Switch

Manual vehicles/'latched' switch (see page 42 for automatic vehicles or 'momentary' type switch.

The factory 'Race Pack' option is equipped with a 4 mode selectable switch which also includes Lotus Launch Control. These modes are controlled from the Lotus DPM switch positioned outboard of the steering column above the light switches.

Note: 'Race' and Lotus DPM 'Off' modes can only be selected whilst the engine is running, but can be activated either whilst the vehicle is being driven or is stationary.

Note: To fully optimise the Exige's set-up for track day usage in dry conditions, it is recommended that the combination of 'Race' Pack suspension and optional Pirelli PZero Trofeo tyres are fitted. This set-up will fully utilise the characteristics of the DPM setting 'Race Mode'.

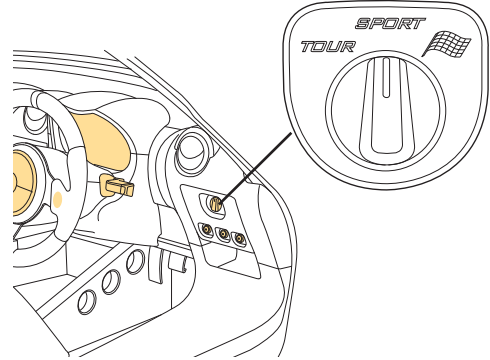

⚠ WARNING: Be aware that selecting 'Sport', 'Race' or Lotus DPM 'Off', will alter the handling characteristics of the car. Drivers should exercise caution until familiarity has been gained in a controlled safe environment.

⚠ WARNING: Under no circumstances should Lotus Launch Control be employed on the public road.

Mode Settings

- TOUR** 1.Lotus DPM fully activated (see Service Notes Section JM.10 for further details).
- 2.Exhaust valve will only open at high throttle applications (see Service Notes Section EM.12 for further details).
- 3.Maximum continuous engine speed restricted to 6600rpm.

- SPORT** 1.Reduction in Lotus DPM settings increasing power induced wheel slippage thresholds and no throttle reduction on understeer.
- 2.Exhaust active valve now open whilst engine idling, closes at low engine speeds and reopens from medium throttle applications/engine speeds.
- 3.Maximum continuous engine speed increased to 7000rpm.

- 'Race' Mode** 1.For dry condition track use only. Optimised traction and corner exit characteristics with reduced Electronic Stability Control (ESC) intervention.
- 2.The exhaust valve is now permanently open regardless of throttle position or engine speed.
- 3.Engine idle speed increased to 900rpm, maximum continuous engine speed increased to 7000rpm.

- Lotus DPM 'Off' Mode** 1.Lotus DPM de-activated.
- 2.The exhaust active valve is permanently open regardless of throttle position or engine speeds.
- 3.Engine idle speed increased to 900rpm and maximum continuous engine speed increased to 7000rpm.

- Launch Control Mode** 1.Lotus DPM optimised for launch control.
- 2.The exhaust active valve is permanently open regardless of throttle position or engine speeds.
- 3.Engine idle speed increased to 900rpm and maximum continuous engine speed increased to 7000rpm.



## Mode Selection

### *'Sport' Mode*

Rotate the switch clockwise from the 'Tour' setting, the amber 'SPORT' tell tale lamp in the instrument panel will be illuminated.

The vehicle will immediately engage 'Sport' mode.

Note: if selected whilst driving, this may cause the exhaust active valve to open without increased throttle pedal depression as well a reduction in the Lotus DPM system functionality.

The Lotus DPM tell tale will flash when electronic intervention is taking place indicating that the systems tractive limit has been reached.

### To Switch Off 'Sport' Mode

Rotate the switch back to the 'Tour' mode position.

Note: If the engine is turned off whilst still in 'Sport' mode the vehicle will revert to 'Sport' Mode when the engine is restarted.

### *'Race' Mode*

Rotate the switch clockwise from either the 'Tour' or 'Sport' setting. Hold the switch for at least one second in the 'Race' mode position and then release, the switch will return to the 'Sport' position.

The amber 'RACE' and Lotus DPM 'Off' tell tale lamps within the instrument panel will now be illuminated. See sub-section MV.5 for further details.

Note: if selected whilst driving, the vehicle will immediately engage Lotus 'Race' mode, the exhaust active valve will open regardless of the throttle pedal position as well a reduction in the Lotus DPM system functionality.

### To Switch Off 'Race' Mode

Rotate the switch back to the 'Tour' position setting.

Note: If the engine is turned off whilst still in 'Race' mode the vehicle will revert to 'Sport' Mode when the engine is restarted.

⚠ **WARNING:** (Lotus DPM) should always be active when driving on public roads in normal conditions.

### Selecting 'Sport' from 'Race' Mode

Turn the switch from the 'Sport' to 'Tour' position then return it back to the 'Sport' mode position setting.

### *Lotus DPM 'Off' Mode*

Note: The vehicle must already be in 'Race' mode to activate the Lotus DPM 'Off' mode.

Ensure the clutch pedal is in the fully up position and rotate the switch fully clockwise from the 'Sport' position and hold for at least one second in the Lotus DPM 'off' position and then release, the switch will return to the 'Sport' mode position.

The 'RACE' tell tall lamp will extinguish but the Lotus DPM 'Off' tell tale lamp will continue to be illuminated. See sub-section MV.5 for further details.

Note: if selected whilst driving, the vehicle will immediately engage Lotus DPM 'Off' Mode, the exhaust active valve will open regardless of the throttle pedal position and the Lotus DPM system will be immediately disabled.

### Cancelling Lotus DPM 'Off' Mode

Rotate the switch back to the 'Tour' mode position. If the engine is turned off whilst still in Lotus DPM 'Off' mode the vehicle will revert to 'Sport' mode when the engine is restarted.



**Lotus Launch Control**

Launch Control is a technique designed to produce the fastest possible race starts.

⚠ WARNING: Under no circumstances should this track feature be used on the public road.

NOTICE: The extreme loads associated with launch controlled starts will eventually result in a reduction of the transmission (and any associated components) lifespan.

Always allow the clutch to cool and recover before repeating a launch controlled start.

To ensure the continued reliability of the transmission system whilst continuing to offer protection under the standard terms and conditions of the Limited Vehicle Warranty, the Lotus DPM system will not exceed a total of 20 controlled launches without the need to reset the launch control system.

The launch control system can only be reset using designated Lotus computerised diagnostic equipment.

The system is only reset after a dealer vehicle inspection, which may also include any rectification or repair work deemed necessary to safely perform any further controlled launches.

Once the system is reset the launch control section of the maintenance booklet is signed and stamped by the dealer so that another 20 controlled launches can be performed.

Note: There may be a charge associated with this resetting procedure, as well any rectification or repair work required which can be attributed as a direct result of driver abuse.

**Extract from maintenance booklet found in owner's handbook pack**

LAUNCH CONTROL RECORD	LAUNCH CONTROL RECORD	LAUNCH CONTROL RECORD
Mileage: ..... Date: .....	Mileage: ..... Date: .....	Mileage: ..... Date: .....
Lotus controlled launches recorded <input type="checkbox"/>	Lotus controlled launches recorded <input type="checkbox"/>	Lotus controlled launches recorded <input type="checkbox"/>
Driver instigated standing starts recorded <input type="checkbox"/>	Driver instigated standing starts recorded <input type="checkbox"/>	Driver instigated standing starts recorded <input type="checkbox"/>
Clutch operation acceptable <input checked="" type="checkbox"/>	Clutch operation acceptable <input checked="" type="checkbox"/>	Clutch operation acceptable <input checked="" type="checkbox"/>
Gear change operation acceptable <input checked="" type="checkbox"/>	Gear change operation acceptable <input checked="" type="checkbox"/>	Gear change operation acceptable <input checked="" type="checkbox"/>
Clutch fluid level acceptable <input checked="" type="checkbox"/>	Clutch fluid level acceptable <input checked="" type="checkbox"/>	Clutch fluid level acceptable <input checked="" type="checkbox"/>
Driveshaft, joints and gaiter condition <input checked="" type="checkbox"/>	Driveshaft, joints and gaiter condition <input checked="" type="checkbox"/>	Driveshaft, joints and gaiter condition <input checked="" type="checkbox"/>
Engine/transmission oil levels acceptable <input checked="" type="checkbox"/>	Engine/transmission oil levels acceptable <input checked="" type="checkbox"/>	Engine/transmission oil levels acceptable <input checked="" type="checkbox"/>
Additional comments:	Additional comments:	Additional comments:
Launch control reset? Yes <input type="checkbox"/> No <input type="checkbox"/>	Launch control reset? Yes <input type="checkbox"/> No <input type="checkbox"/>	Launch control reset? Yes <input type="checkbox"/> No <input type="checkbox"/>
Dealer stamp:	Dealer stamp:	Dealer stamp:
Dealer's signature: .....	Dealer's signature: .....	Dealer's signature: .....

20

For further information please refer to the 'OBLIGATIONS OF OWNERS' and 'WARRANTY NOTES' sections of the New Vehicle Warranty manual which is included as a separate publication contained within the owner's handbook pack.

Note: As from the time of the last dealer visit, a cumulative total of all the controlled launches as well as manually instigated vehicle standing starts will be displayed in the vehicles maintenance record book. Also see the Engine Data Recording section on page 64 for further information. This book is also included as a separate publication contained within the owner's handbook pack.

Note: The repair or replacement of any transmission components required as a result of damage or premature wear will not be covered under the terms of the Limited Vehicle Warranty once the Lotus DPM system has recorded in excess of 100 Lotus controlled launches.

Therefore it is highly recommended that the total number of controlled launches performed to date is taken into account before any further launch attempts are considered.

Note: The repair or replacement of any transmission components required as a result of damage or premature wear will not be covered under the terms of the Limited Vehicle Warranty if any driver instigated manual standing start launches have been recorded.

For a full explanation of the terms and conditions of the Lotus Limited Vehicle Warranty, please refer to the separate warranty manual contained within the owner's handbook pack.





Activating Launch Control

Note: Launch control can only be activated if the Lotus DPM system is currently set to 'Race' mode

1. With clutch pedal depressed and the Lotus DPM system currently set to 'Race' mode, rotate the switch clockwise from the 'Sport' mode position and hold for at least one second in the 'Race/Launch' mode position and then release.

The switch will return to the 'Sport' mode position.

Launch Control Preparation

To perform the best possible race start whilst also ensuring powertrain wear is limited, the engine and Lotus DPM systems will carry out the various checks before allowing the vehicle to perform a controlled launch.

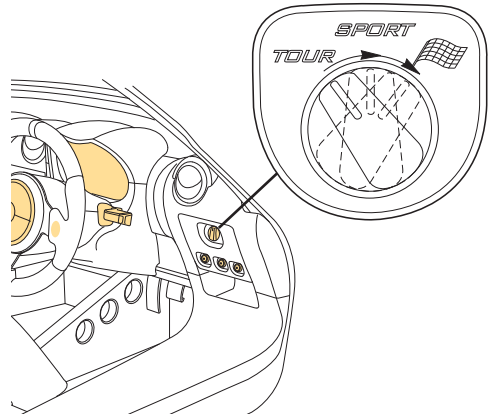

Vehicle parameters required to perform a Lotus DPM assisted controlled launch:

- Vehicle must be stationary.
- Engine coolant temperature must be between 80°C and 110°C.
- Steering wheel must be in the straight ahead position.
- A Lotus controlled launch has not been performed within the last 2 minutes.
- There are no system faults present causing in either the MIL (Malfunction Indicator Light) or Lotus DPM tell tale lamps to be illuminated, see sub-section MV.5 for further information.
- Current vehicle mileage is in excess 500 miles / 805 km.

Unless all of these conditions are within the set tolerance ranges the LCD screen will show the RH message for 2 seconds before returning back the standard display.

If all of the conditions are within the set tolerance ranges then the LCD screen will display this message.



2. To proceed with launch mode rotate the switch clockwise once more from the 'Sport' mode position and hold for at least one second in the 'Race/Launch' mode position and then release.

The LCD display will then display this flashing message.



Note: There are no limitations on how many times the vehicle can be put into launch mode.

3. Engage first gear and apply full throttle. This will set the maximum engine speed to match the launch controlled rev-limited maximum engine speed (3500 rpm approx).

NOTICE: Do not attempt a launch controlled start in any gear other than first.

Note: Full throttle must be applied within 1 second of the engine speed being raised up to or above the launch



controlled rev-limited speed otherwise launch control will be aborted and the 'Launch Denied' message will be displayed.

To protect the exhaust catalysts from overheating, the Lotus DPM system will cancel launch mode if the engine speed is held at or above the launch controlled rev-limited maximum for a cumulative time of more than 10 seconds.

4. Rapidly release the clutch and maintain full throttle throughout the transition from 'Launch' to 'Race' mode until the first gear change is required.

NOTICE: Do not attempt to slip the clutch during a controlled launch start as overheating or damage to the clutch mechanism may occur.

A controlled launch can be cancelled before completing stage 2 by releasing the clutch pedal, or at any stage by turning the Lotus DPM switch to either the 'Sport' or 'Tour' mode.

The Lotus DPM system will return to 'Race' mode once the launch procedure has been carried out and the driver makes the first gear change.

Repeat steps 1- 4 to carry out another controlled launch (waiting for at least 2 minutes to elapse since the previous launch).

Launch control functionality is inhibited after 20 Lotus controlled launches have been performed,

If any further controlled launches are attempted then the LCD display will display the this message and an audible buzzer will sound.



The launch control system must be reset by a Lotus dealership to permit a further 20 controlled launches to be performed.

**Engine Protection Valve Override Switch (If fitted)**

The EP valve may be returned to the closed position whilst the vehicle is in 'Race' or Lotus DPM 'Off' mode by a momentary press of the override switch located on the left hand side of the steering column console.

This may be required if driving the vehicle on a noise restricted track. Alternatively if pressed whilst in 'Tour' or 'Sport' mode, the EP valve will open regardless of the vehicle road speed.

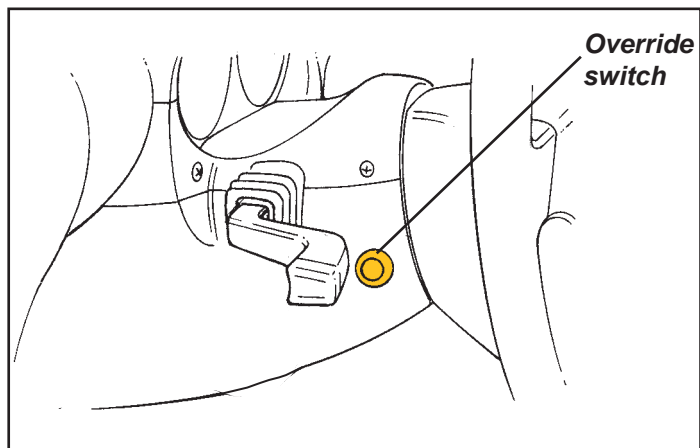

A corresponding "EX.OPEN" or "EX.SHUT" message will also be momentarily shown by overriding the fuel gauge display within the instrument panel.

Note: Even if overridden, the EP valve will automatically open if the engine speed exceeds 5500rpm to reduce excessive back pressure.

The EP valve will return to the closed position when the ignition is switched off.

**LOTUS DPM SWITCH OPTIONS FOR AUTOMATIC VEHICLES***Lotus DPM switch*

The 'latched' type DPM switch is replaced on automatic vehicles by a 'momentary' type switch. Unlike the 'latched type switch, the DPM control knob on automatic vehicles will return to a central position when released with '+' and '-' symbols replacing the 'Tour' 'Sport' 'Race' and 'DPM Off' graphics displayed on the 'latched' switch still currently fitted to manual transmission models.

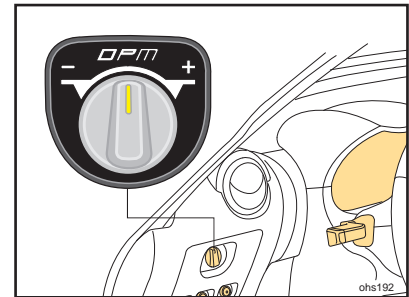

With the exception of 'Lotus Launch Control' the Lotus DPM (Dynamic Performance Management) system options as shown for manual vehicles on the previous pages are also available for automatic vehicles but with an alternative method of selection.

Note: Lotus DPM 'Off' mode can only be selected whilst the engine is running, but can be activated either whilst the vehicle is being driven or is stationary.

**⚠ WARNING**

Be aware that selecting Sport Mode and/or Lotus DPM 'Off' will alter the handling characteristics of the car. Drivers should exercise caution until familiarity has been gained in a controlled safe environment.

**Lotus DPM Mode Settings****TOUR** 1. Lotus DPM fully activated.

2. Exhaust active valve will only open at high throttle/RPM applications.
3. Maximum continuous engine speed restricted to 6,600rpm.
4. Manual Gear Selection Mode can be selected, see service notes section FB.3 for additional information.

**SPORT** 1. Reduction in Lotus DPM settings allowing increased power induced wheel slippage thresholds and no throttle reduction on understeer.

2. Exhaust active valve now open whilst engine idling, closes at low engine speeds and reopens from medium throttle applications/engine speeds.
3. Maximum continuous engine speed increased to 7,000rpm.
4. Gear shift points are optimized for improved vehicle performance and faster gear shifts and, if activated, the vehicle will remain in Manual Sequential Gear Mode until the D – Drive button is depressed, see service notes section FB.3 for additional information.

**LOTUS** 1. Lotus DPM de-activated.**DPM** 2. Exhaust active valve opening timing carried over from 'Sport' mode**'OFF'** 3. Maximum continuous engine speed increased to 7,000rpm.

4. Gear shifting points and manual sequential gear mode functions are carried over from 'Sport' mode.

**RACE** 1. For dry condition track use only. Optimised traction and corner exit characteristics with reduced Lotus DPM intervention.

2. The exhaust valve is now permanently open regardless of throttle position or engine speed.
3. Maximum continuous engine speed increased to 7,000rpm.



Mode Selection



'Tour' Mode

**FOR NORMAL ROAD USE**

Lotus DPM switch will remain in the central position for the default 'Tour' mode unless turned clockwise to activate other available DPM settings.

The Lotus DPM tell tale within the instrument panel display will flash when electronic intervention is taking place indicating that the systems tractive limit has been reached.

X1

'Sport' Mode

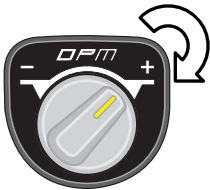

**ONLY FOR SUITABLE ROAD CONDITIONS**

With the ignition on or the engine running, rotate the Lotus DPM switch clockwise ONCE from the central 'Tour' position to '+' symbol and then release.

The switch will return to the central position and the amber '**SPORT**' tell tale in the instrument panel will be illuminated. The vehicle will immediately engage 'Sports' Mode. If selected whilst driving, this may cause the exhaust active valve to open without increased throttle pedal depression as well a reduction in the Lotus DPM system functionality. The Lotus DPM tell tale will flash when electronic intervention is taking place indicating that the systems tractive limit has been reached.

X1

To Switch Off 'Sport' Mode



Rotate the switch counter clockwise ONCE from the central position to the '-' symbol and then release. The vehicle will revert back to 'Tour' Mode when the ignition is turned off.

X1

Race Mode (If fitted)



**FOR TRACK USE ONLY**

*If selected from Sport mode:* With the engine running, rotate the Lotus DPM switch clockwise ONCE from the central position over to the '+' symbol for approximately one second and then release.

From 'Sport' mode

*If selected from Tour mode:* With the engine running, rotate the Lotus DPM switch clockwise TWICE from the central position over to the '+' symbol and then release.

X2



The switch will return to the central position, the amber **RACE** and Lotus DPM 'Off' tell tale lamps within the instrument panel will now be illuminated, see previous pages for further details. If selected whilst driving, the Lotus DPM system functionality will be reduced, the vehicle will immediately engage Race mode and the exhaust active valve will open regardless of the throttle pedal position.

From 'Tour' mode



**To return to 'Sport' mode from 'Race' mode**

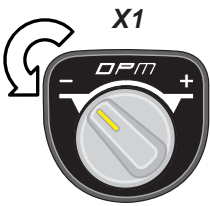

Rotate the switch counter clockwise ONCE from the central position to the '-' symbol and then release.

**To return to 'Tour' mode from 'Race' mode**

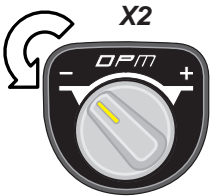

Rotate the switch counter clockwise TWICE from the central position to the '-' symbol and then release. The vehicle will revert back to 'Tour' Mode when the ignition is turned off.

**X1 Lotus DPM 'OFF'**

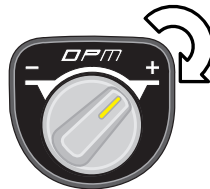

**FOR TRACK USE ONLY**

*If 'Race' option not fitted:* With the engine running with 'Sport' mode already selected, rotate the Lotus DPM switch clockwise ONCE from the central position over to the '+' symbol and then release.

*If 'Race' option fitted:* With the engine running with 'Race' mode already selected, rotate the Lotus DPM switch clockwise ONCE from the central position over to the '+' symbol for approximately one second and then release. The Lotus DPM 'Off' lamp within the instrument panel will now be illuminated and the vehicle will immediately engage Lotus DPM 'Off' Mode. If selected whilst driving, this may cause the exhaust active valve to open without increased throttle pedal depression as well a reduction in the Lotus DPM system functionality.

**X1 To Switch Off Lotus DPM 'Off' Mode**



*If 'Race' mode fitted:* Rotating the switch counter clockwise ONCE from the central position to the '-' symbol will return the vehicle to 'Race' mode. If 'Race' mode is not fitted this will return the vehicle to 'Sport' mode.

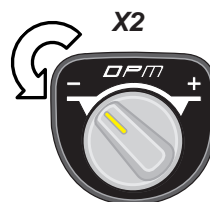

Rotating the switch counter clockwise TWICE from the central position to the '-' symbol will return the vehicle to 'Sport' mode'. The vehicle will revert back to 'Tour' Mode when the ignition is turned off.



MV.8 - WIPER MECHANISM

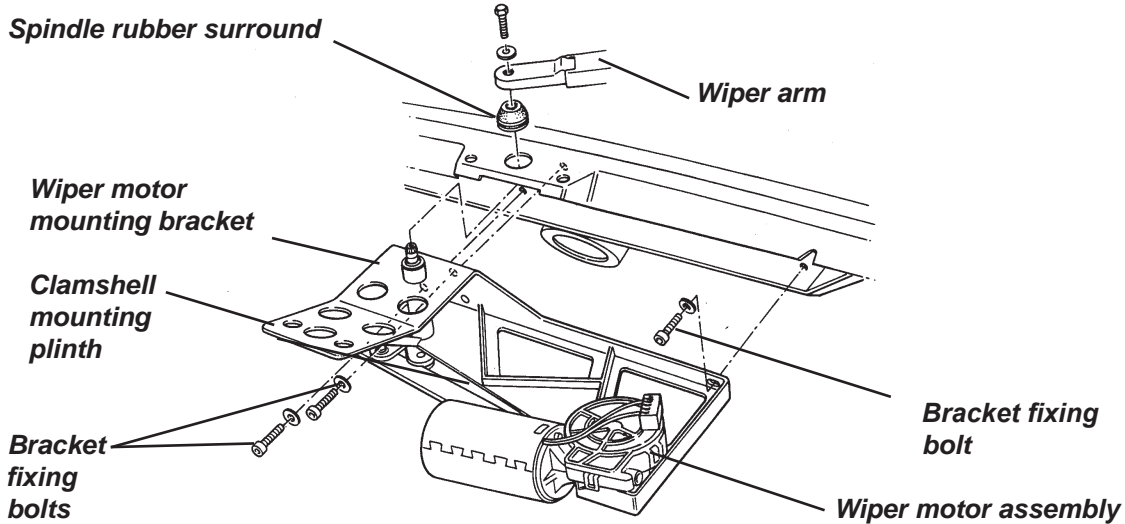

m208

The windscreen wiper mechanism comprises a uni-directional motor with an external rotary link, a connecting rod, and a pair of actuating links which join the connecting rod to the arms of the wiper spindle. This mechanism provides the wiper with a motion which is slowed at each end of its travel in order to ease the inertia loads during direction changes, to the benefit of refinement and durability.

The motor and wheelbox are mounted on a single fabricated steel bracket which is bolted to the windscreen scuttle panel.

**Wiper Blade**

To replace the wiper blade, lift the arm away from the windscreen, swing the blade through 90°, depress the retaining tab and slide the blade down the arm to unhook and release.

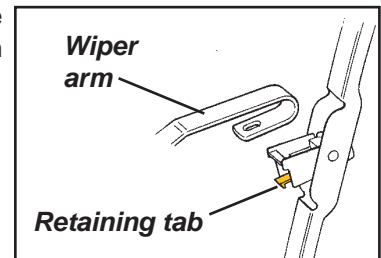

**Wiper Mechanism**

Removal:

1. Remove the front clamshell (see sub-section BT.6).
2. Carefully place the main fuse box with bracket assembly and place to one side ensuring that no unnecessary strain is placed on the wiring harness or connections. See sub-section MV.12 for further information.
3. Remove the ducting between heater/a.c. unit and air distribution unit.
4. Remove the wiper motor protective cover by releasing the two screws into the windscreen buttress and cable tie securing the cover to the wiper motor and withdraw from the vehicle.
5. Disconnect the harness plug from the motor (cutting cable tie if fitted),
6. Disconnect the washer tubing from the washer jets and position hose to one side.

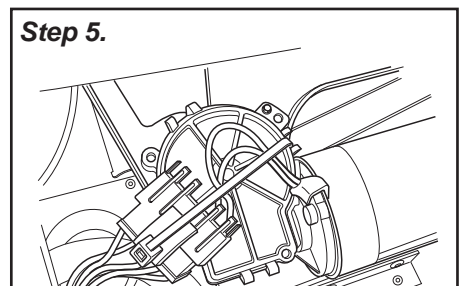
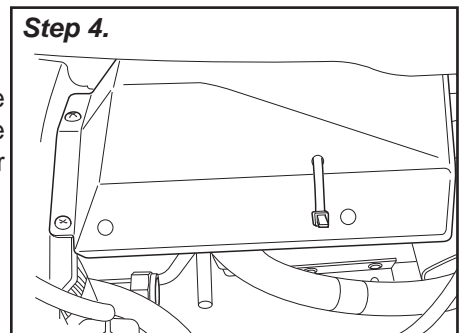



7. Lift up the wiper arm nut cover and lift the wiper arm away from the windscreen
8. Mark the position of the wiper arm in relation to the wiper spindle
9. Remove the nut securing the wiper arm, gently moving the arm to release it from taper of the wiper spindle.
10. Remove the wiper arm from the spindle, and the spindle rubber surround.
11. Release the nuts securing the washer jets to the windscreen frame and remove them (this may be necessary to ensure the motor and mounting frame can be withdrawn from the vehicle).
12. Release the three screws securing the motor mounting bracket to the windscreen frame - one at each side of the spindle, one at the motor end, and withdraw the complete mechanism from the car.
13. If the motor is separated from the mechanism, the position of the rotary link should be marked against the motor shaft for reference when re-fitting. The motor should be in the 'park' position before fitting and the mechanism at full travel so that the rotary link and connecting rod are aligned in the fully extended position.
14. Re-assemble in the reverse order to removal, torque tightening the bracket bolts to 20 Nm.

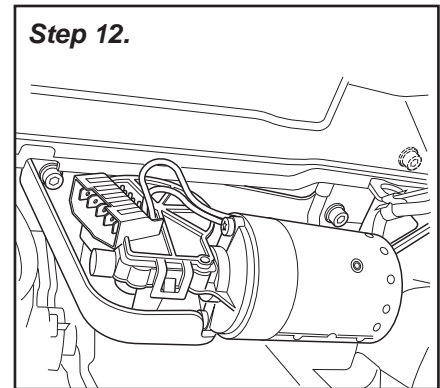
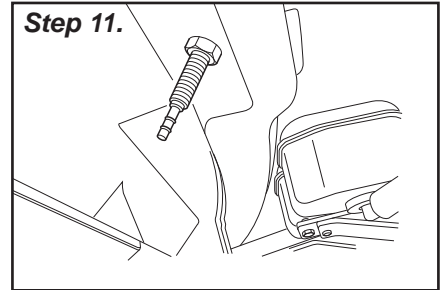

**Step 13.**

**RHD Shown**  
**(LHD symmetrically opposite)**

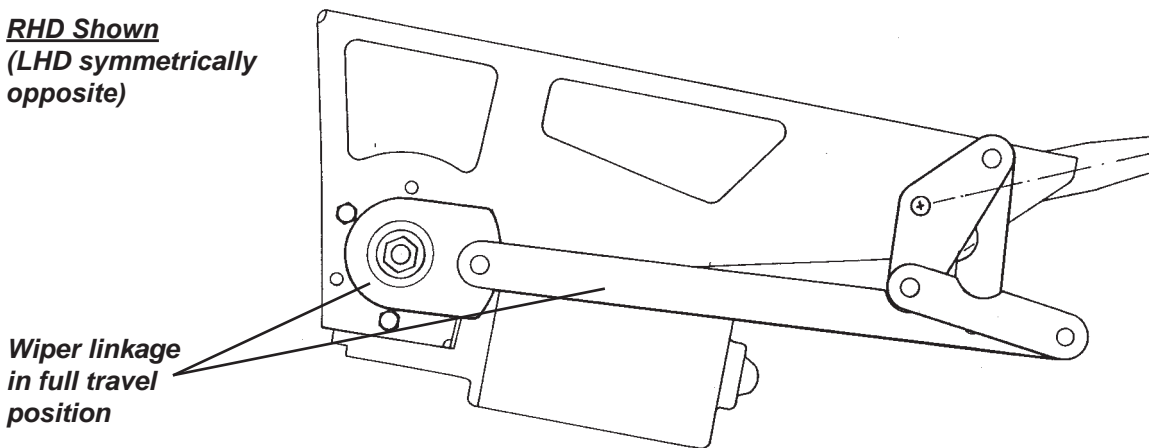

m209



Washer motor/bottle

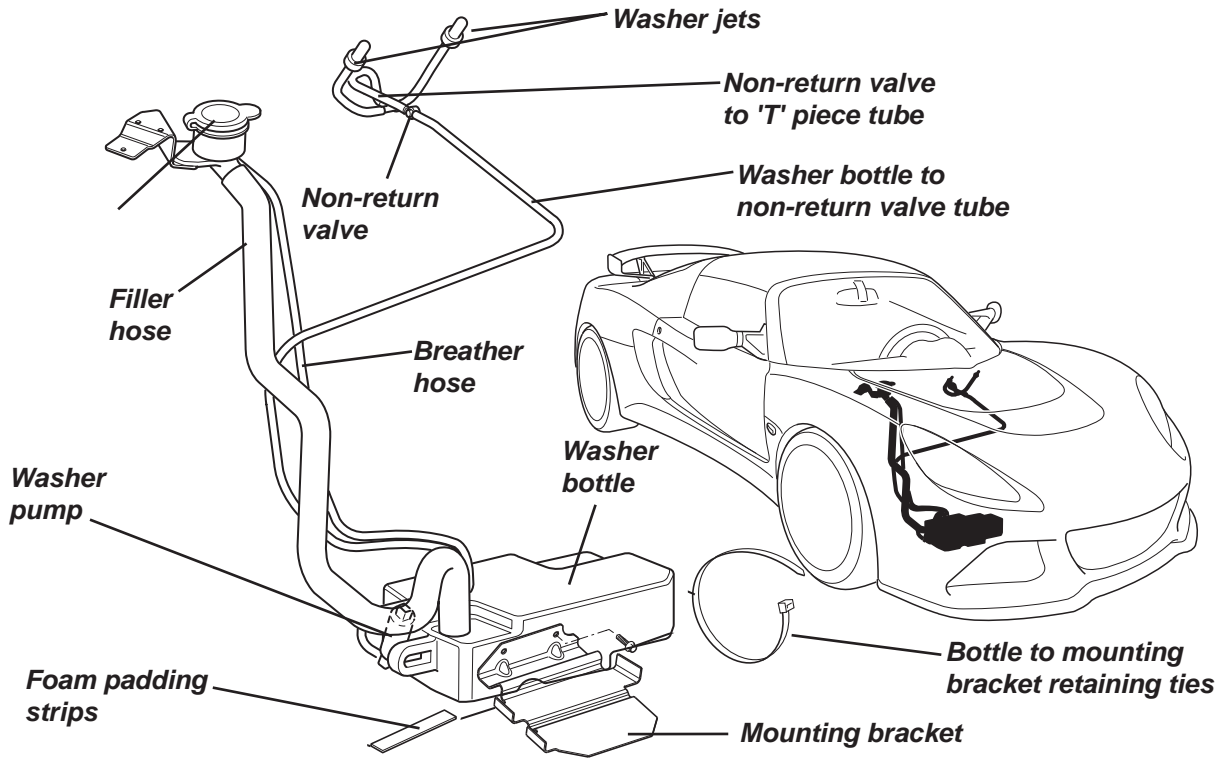

Washer Jets

The washer jets are mounted each side of the wiper spindle, and may, if necessary, be cleared or adjusted using a suitable pin. A non return valve is fitted in the tubing line near to the 'T' piece connector joining the left and right washer jets.

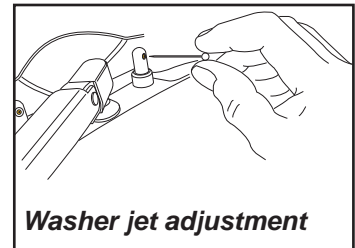

Washer Reservoir Cap Access

Release and remove the cover, see service note section BT.2 for further informaton. The filler tube is identified by its blue filler cap and  symbol.

*Topping up:* Prise off the blue filler cap and top up with clean water and a suitable washer fluid, refit the cap securely and refit the access cover. For reservoir capacity and recommended washer fluid specification see service note section TDV - Vehicle Data for further information.

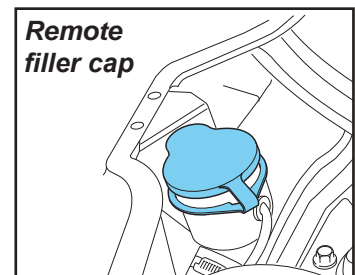

Washer Reservoir

The windscreen washer bottle is located on the underside of the crash structure, supported by a mounting bracket which is fixed with M6 x 16 screws (2) to the vehicle chassis.

The washer bottle is additionally retained to the mounting bracket by two tie wraps fixed around the bottle and bracket. Foam strips are fitted between the underside of the bottle and bracket.

The washer motor is push fitted into a grommet at the RH side of the bottle

The remote reservoir filler hose, breather and washer tubing are routed between RH outside of the crash structure and wheelarch liner, passing through an aperture in the side of the crash structure and then connected the washer bottle/motor.

Access to the washer motor/bottle will require the removal of the front under shield, see service notes section AN.3 for additional information.





MV.9 EXTERIOR LIGHTING

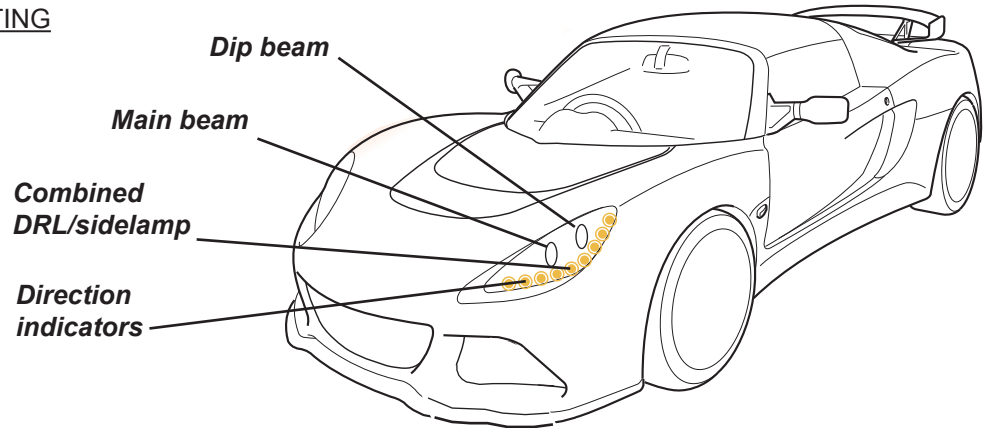

**Headlamps**

The headlamp assemblies incorporate halogen main and dip beam lamps with replaceable bulbs, LED amber string direction indicators and an LED white string of DRLs (Daytime Running Lamps)/side lamps (which can only be renewed as part of the complete headlamp assembly). The lamp components are enclosed in a polypropylene housing and protected by a polycarbonate clear lens cover.

When the engine is started, the front sidelamps will automatically be activated as daytime running lamps, with the front sidelamps operating with an increased intensity. When the ignition is turned off, the DRLs will switch off automatically unless manually selected.

If the sidelamp switch is activated whilst the engine is running the front DRLs will revert to their sidelamp functionality and operate with a reduced intensity.

*Alignment:*

The alignment relationship between high and low beam lamps is fixed, but two adjusters are provided on the back of the headlamp housing by which the whole lamp unit may be adjusted.

*Adjustment:*

If adjustment to headlamp alignment is required, remove the access cover in the wheelarch liner, see Service Notes section BT.5 for further information.

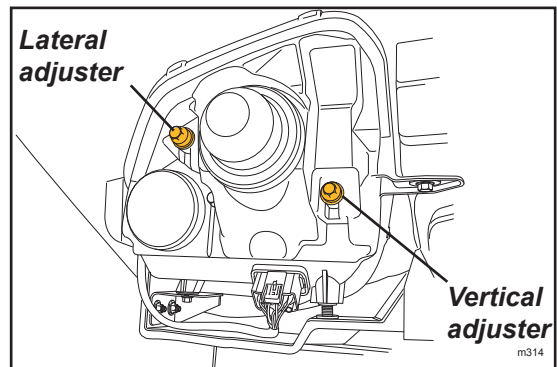

To adjust the beam laterally, turn the outboard hexagonal adjuster screw. Optimum setting is 0%.

To adjust the beam vertically, turn the inboard adjuster screw. Optimum setting is -1.2%.

*Bulb replacement:*

*Preparation:* Remove the access cover in the wheelarch liner, see Service Notes section BT.5 for further information.

*Dip beam bulb:* Remove the protective boot from the back of the inboard lamp, twist the bulb holder counterclockwise, and withdraw from the lamp. Prise open the retaining barbs to allow the harness plug to be disconnected. Replace the 12V 60W type HB3A bulb, and reassemble in reverse order to disassembly.

*Main beam bulb:* Remove the protective boot from the back of the outboard lamp, withdrawing the bulb is similar to the above except that the harness connection uses separate spade terminals (may be connected either way round). The main beam bulb is 12V 65W type H9B.

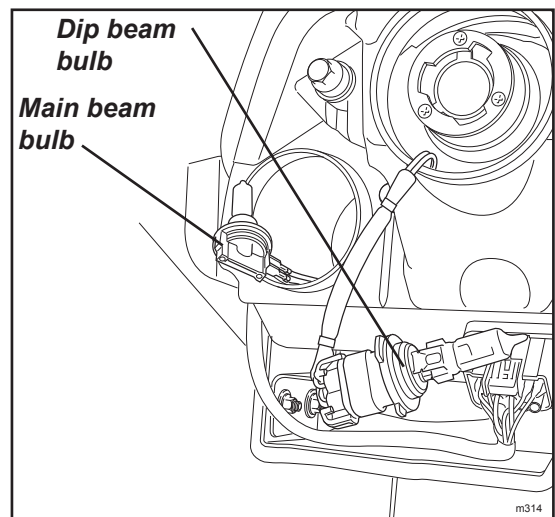



**Headlamp Repair**

Except for the replacement of the dip and main beam bulbs, the headlamp assembly is considered a non-serviceable unit. The only exception to this is the repair/replacement of the dip beam bulb internal harness plug including a partial section of the feed and return wires.

Replacement of the plug/partial section of the harness may be required in the event that either the plug becomes damaged during dip beam bulb removal, or if dip beam bulb fails to operate due to a loss of continuity in wires at the proximity of the harness plug.

A headlamp harness repair kit is available under Lotus part number A120M0106F

Note: It is highly recommended to carry out this repair to both headlamp assemblies even in the event that only a single headlamp harness has failed, the harness repair kit part number listed above consists of repair harnesses.

*Procedure:*

Repair Procedure for the left hand headlamp (right hand similar)

1. Prise open the retaining clip and disconnect the harness plug from the dip beam bulb.
2. Using side cutters remove the tie wrap securing the protective sheathing to dip beam harness wires.
3. Pull back the sheathing as far as possible to expose harness wires.
4. Using suitable automotive wire cutters, cut both harness wires approximately 2cm from the end of the sheath and then strip approximately 5mm of the outer insulation covering on both wires.

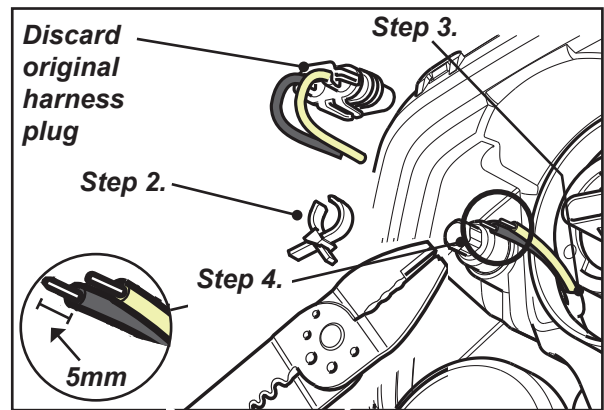

5. Fit the in-line splice/heat shrinks of the repair harness (A120M0106F) fully onto the exposed headlamp harness cores as follows:

Headlamp harness		Headlamp repair harness
Wire colour		Wire colour
Beige	→	White
Black	→	Black

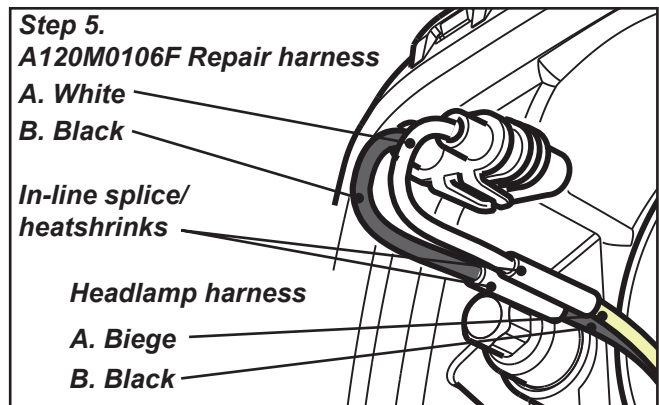

6. Ensuring that the heat shrinks are covering the outer insulation of the headlamp harness wires, crimp the splices to secure the repair harness wires to the headlamp harness wires.

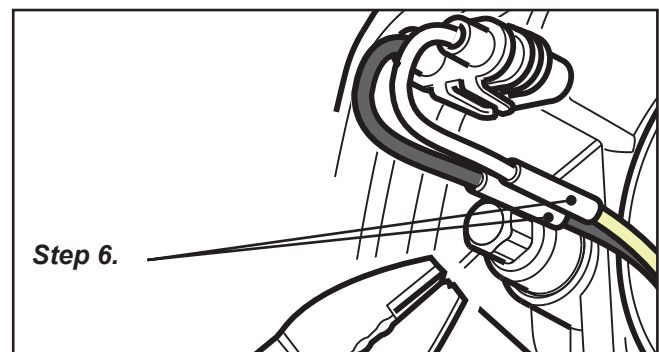



- 7. Once secure, use a suitable hot air gun to apply localised heat to melt the heat shrinks to the headlamp harness wires.

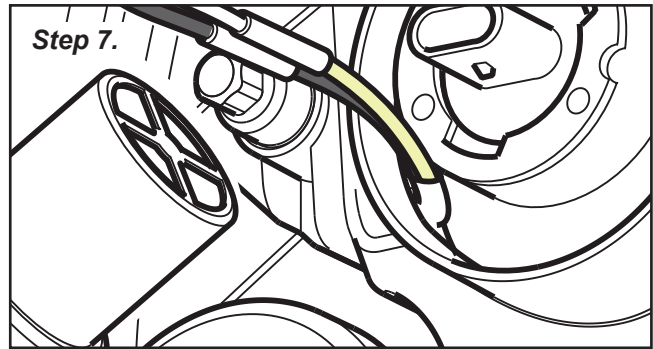

- 8. Fit the protective sheath over the in-line splices covering the repair harness wires as far as possible and fit a new tie wrap to the sheath.

- 9. Connect the harness plug back onto the dip beam bulb connector terminal

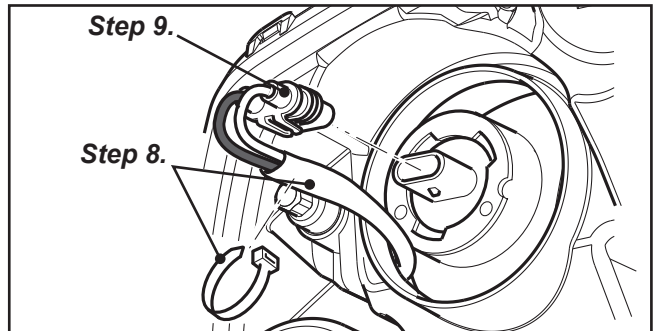

- 10. Push the sheath protected harness back into the headlamp housing.

- 11. Ensure the harness repair harness wires are routed so that they are clear of the dip beam reflector housing.

- 12. Check the operation of the headlamp, refit the dip beam bulb protective boot, wheelarch access panel and road wheel.

- 13. Repeat the above steps for the right hand headlamp.

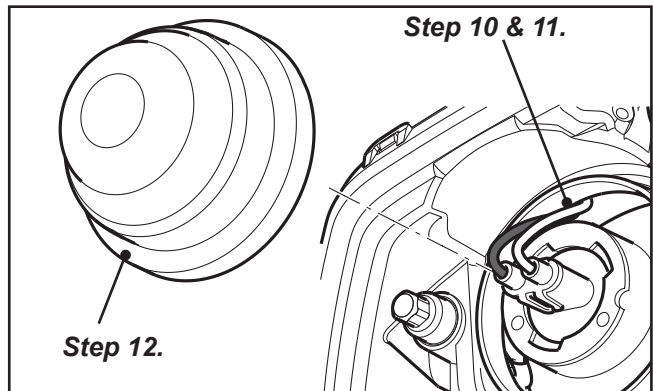



Headlamp beam masking

The headlamp assemblies are not fitted with any internal masking facility. Therefore if it is necessary to drive a RHD vehicle in an opposite drive hand territory the low beam 'kick up' bias should be masked to prevent dazzle.

Proprietary adaptor kits such as 'Eurolites Headlamp Beam Adaptors' can be purchased from many different motorists stores and used for a limited time period on the headlamp assemblies.

The correct positioning of any adaptor is critical to ensure that only the dipped headlamps 'kick up' bias beam is masked without affecting the its horizontal beam pattern.

Lotus has produced beam converter templates that will aid in the fitting of suitable masking/adaptor kits, ensuring that they are positioned correctly on the headlamp lens so masking the 'bias' beam pattern area without disrupting the horizontal pattern.

Template information:

Part Number	Description	Qty
LSL 604	Beam converter template, driver's side - RHD	1
LSL 605	Beam converter template, passenger's side - RHD	1

The above template part numbers are available to download and print from the Lotus Dealer Portal. From the homepage go to - Miscellaneous Technical Information>Instructional Guides.

LSL 604 Beam converter template

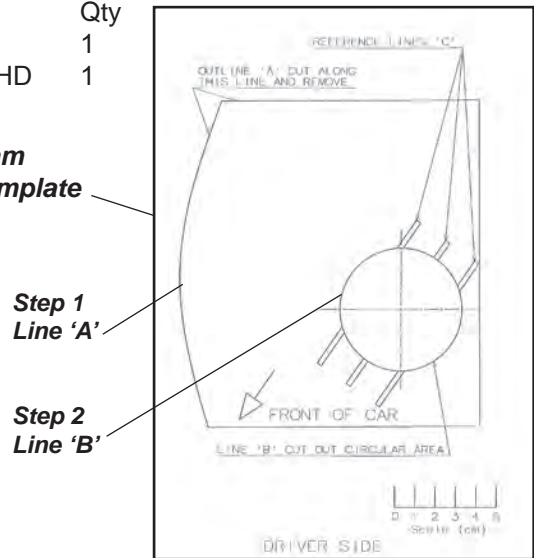

Step 1 Line 'A'

Step 2 Line 'B'

Masking procedure:

1. Cut along contour line (A) and remove this portion of the template.
2. Cut out the circular area (B) of the template.
3. Clean the lenses and activate the lamps per the Beam Adaptor manufacturer's recommendations which can be found in the included fitting kit.
4. Lay the 'Drivers Side' template onto the driver's side headlamp lens using the inner line of the black 'frame' as a guide. Hold in place on the lens with 3 small pieces of masking tape.
5. Peel off the backing paper from the circular section of the beam adaptor and position centrally inside the circular area of the template ensuring the adaptor lines are in the same orientation as the reference lines 'C' on the template.

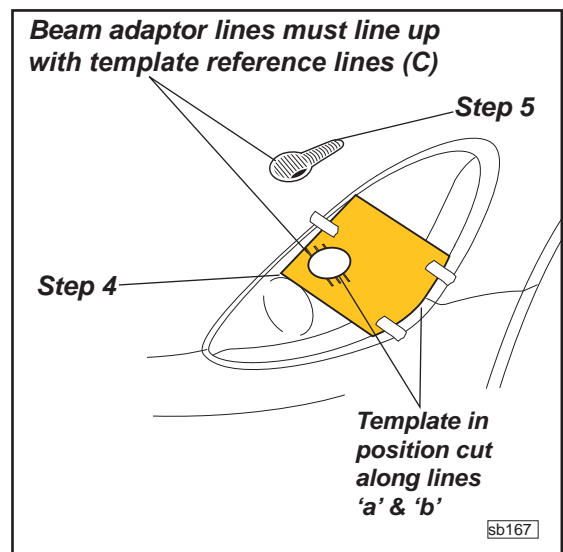

Beam adaptor lines must line up with template reference lines (C)

Step 5

Step 4

Template in position cut along lines 'a' & 'b'

Sb167



6. Remove the template.

7. Tear off the tail portion of the beam adaptor

Repeat the process using the 'Passenger Side' template for the passenger side headlamp.

For removal of the Beam Adaptors, follow the adaptor manufacturer's instructions and recommendations.

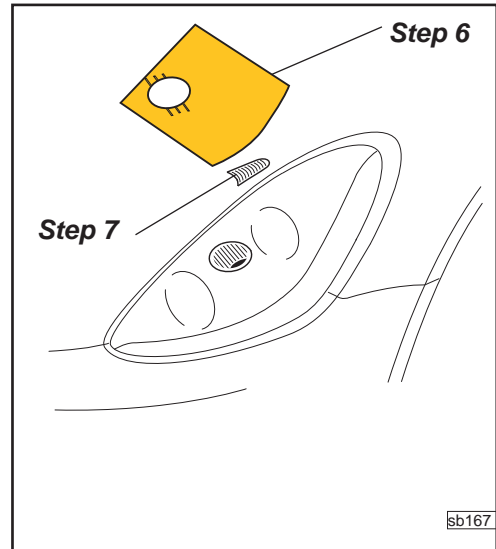

**Note:** Self adhesive beam adaptors should be used for as minimum of period as possible, and removed as per the manufacturers recommendations.

Continued use of adaptors or their improper removal may, under extreme circumstances, cause irreversible marking of the headlamp lens which will not be considered a Lotus manufacturing defect and not liable under the vehicles limited vehicle warranty.

It is recommended to replace the vehicles headlamp assemblies to LHD units for continued use in an opposite hand drive territory.

**Headlamp removal:**

Remove the headlamp access panel from within the wheelarch liner area; see Service Notes section BT.5 for further information.

1. Disconnect the main harness connector from the headlamp terminal.
2. Remove the M6 x 14 bolt and washer securing the headlamp upper outboard mount to the clamshell (note, there may also be spacers fitted between the headlamp mounting lug and clamshell).
3. Remove the M6 x 16 bolt fitted into the headlamp brass 'top hat' mounting adjuster which can be wound in and out of the headlamp to align the headlamp lens to the clamshell.
4. Remove the M6 x 14 bolt and washer securing the headlamp to the crash structure bracket. (Note this bracket can also be moved up and down on its slotted apertures to align the headlamp lens to the clamshell).
5. Remove the M6 x 12 bolt and washer securing the front of the headlamp to the clamshell (not illustrated).

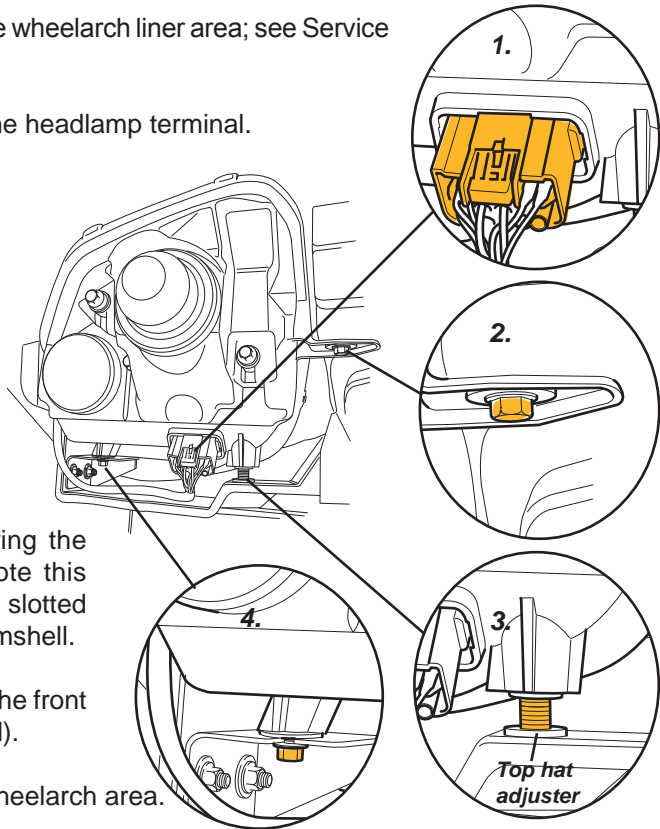

The headlamp can now be withdrawn from the wheelarch area.

**Refitment:**

Is the reverse of removal except that headlight positioning (as per steps 2,3 & 4) may have to be adjusted to ensure that it is sitting flush with the profile of the clamshell, and adjust beam alignment if required as shown on the previous page.

**Side repeater lamps**

Located within the door hinge cover 'A' panels, the side repeater lamps flash in unison with the front and rear indicator lamps. Using LED's (Light Emitting Diodes) the lamps are not serviceable and must be replaced as a complete assembly in the event of failure.

**Removal:**

It is retained to the 'A' panel by an adhesive backing which is integral to the rear body mounting face of the lamp.

Carefully prise the lamp away from the 'A' panel so breaking its adhesive bond.

Disconnect the lamps flylead connector from the main vehicle harness multiplug and withdraw from the vehicle.

**Refitting:**

Is the reverse of removal.

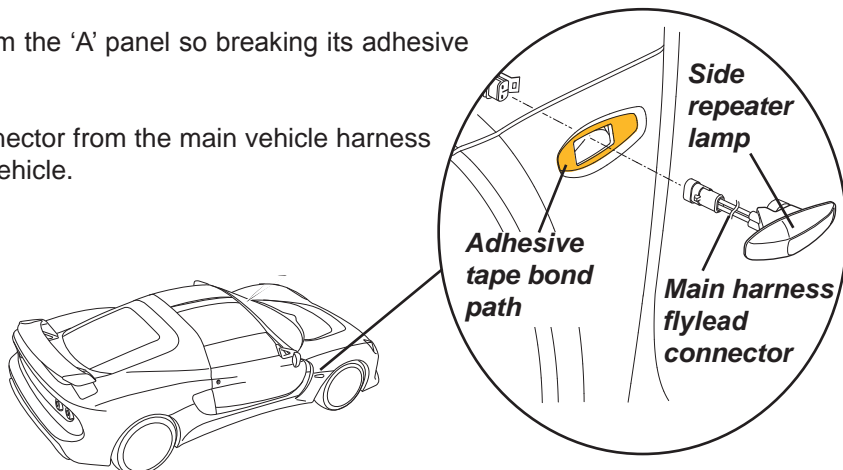



Licence plate lamps

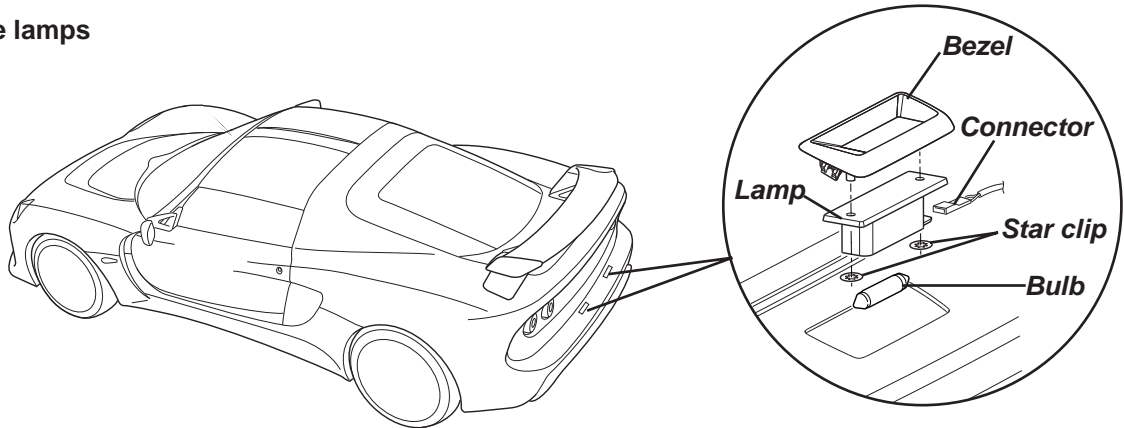

Removal:

Withdraw the lamp assembly away from the bumper by carefully prising the lamp bezel away from the rear bumper releasing it from its integral securing clips.

Bulb removal:

The festoon bulb can then be removed from its electrical connections within the transparent lamp housing.

Lamp renewal:

The lamp can be separated from the bezel by carefully removing the star clips from the lamp housing securing posts.

LED Rear Lamps

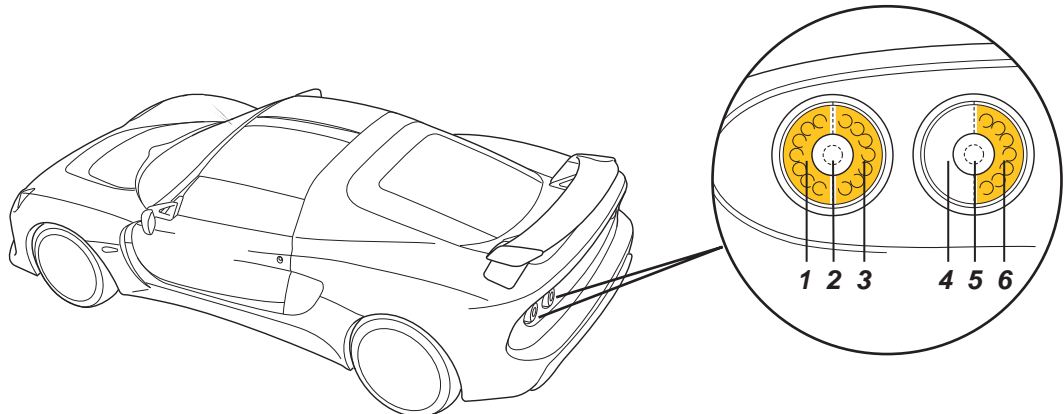

The rear lamp clusters incorporate LEDs (Light Emitting Diodes) in the annular segments of the lamps. The central elements continue to use filament bulbs.

The LEDs are extremely durable and are serviced only by lamp cluster replacement. The turn indicators in the centre of the outboard lamps, and the reverse lamps in the centre of the inboard units, use W16W bayonet fitting filament bulbs in twist release holders.

Lamp Configuration - filament bulb & LED types (LH lamps shown)

Outboard lamp

Function	Bulb type
1. Tail and brake lamp	LED
2. Direction indicator	Capless 12V 16W W16W
3. Tail and brake lamp	LED

Inboard lamp

Function	Bulb type
4. Not used	N/A
5. Reverse lamp	Capless 12V 16W W16W
6. Rear fog lamp	LED



*Lamp security*

Integral studs fitted to the rear lamps fix them to the rear transom panel.

*Removal:*

Remove the applicable lamp cover located within the rear luggage compartment.

Disconnect the harnesses of both ballast modules at their multi-plug connections to the RH & LH outer lamp fly leads.

Disconnect the rear harness within the luggage compartment to the lamp(s) fly lead multi-plug connector.

Remove the M5 nyloc nuts and M5 washers securing the lamp(s) to the transom panel.

The lamp(s) can now be withdrawn away from the transom panel.

*Refitment:*

Is the reverse of removal, ensure the lamps are fitted in the correct rotation.

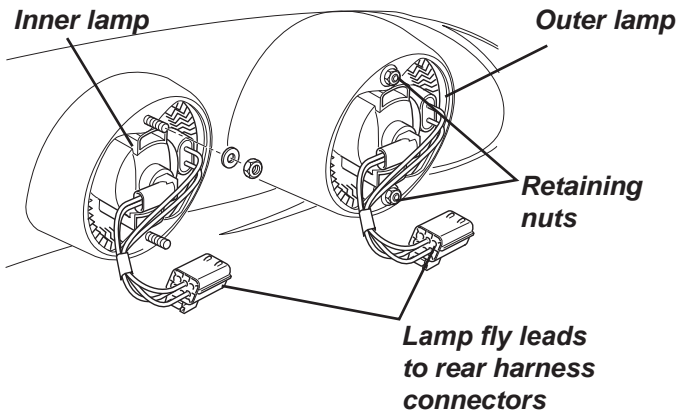

**Centre High Mount Stop Lamp (CHMSL)**

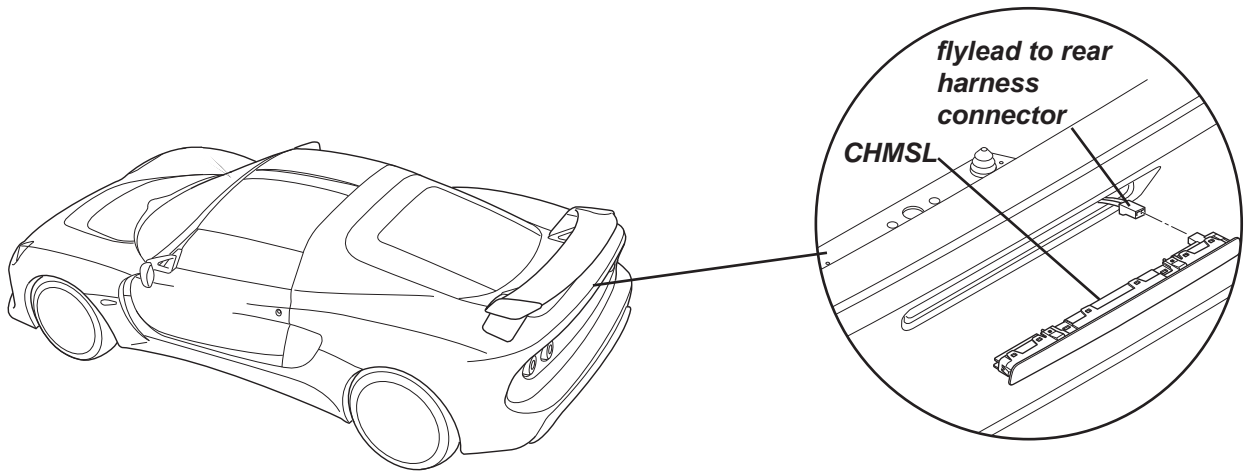

Located within rear clamshell above the transom panel, it illuminates in unison with the brake lamps.

Using LED's (Light Emitting Diodes) the lamp is not serviceable and must be replaced as a complete assembly in the event of failure.

*Removal:*

It is retained to the clamshell panel with integral clips moulded into the CHMSL body.

Prising it out directly from the clamshell may break the integral clips. It is recommended to remove the tailgate latch cover to gain access to the rear of the CHMSL so that its integral clips can be pushed in allowing the lamp to be withdrawn out of the clamshell.

*Refitment:*

Is the reverse of removal.





## MV.10 - BATTERY, BATTERY CABLES & EARTHING POINTS

### Battery

**⚠ WARNING: POISON/DANGER - CAUSES SEVERE BURNS - KEEP OUT OF REACH OF CHILDREN.** Contains sulphuric acid - avoid contact with skin, eyes or clothing. If in contact with skin or eyes; flush with copious amounts of water. Remove contaminated clothing. Seek immediate medical attention. If ingested; seek immediate medical attention. Do not induce vomiting or give fluids to drink. Batteries produce explosive gases. Keep sparks, flames and cigarettes away. Ventilate when charging or using in enclosed space. Always shield eyes when working near batteries.

### Battery location

The 72 Ah VARTA BLUE dynamic battery (Varta part number 572409068) is located at the left hand of the rear luggage compartment.

### Battery maintenance

Inspection or topping up of the electrolyte is not required, but at intervals specified in the Maintenance Schedule, the battery terminals should be checked for security and condition, and protected with petroleum jelly.

### Battery access

Remove the left hand compartment trim panel by pulling it away from the luggage compartment releasing it from its velcro fixings.

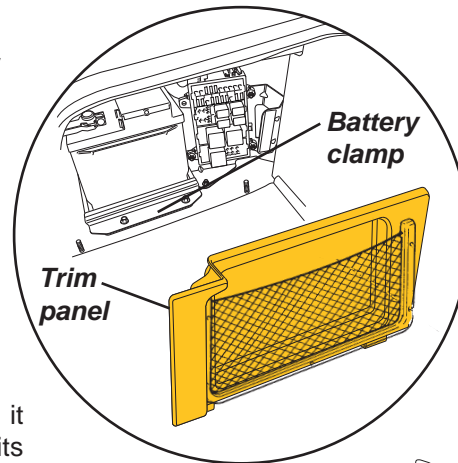

### Disconnecting the battery

**⚠ WARNING: Failure to follow the correct battery disconnection procedure detailed below could result in serious burns.**

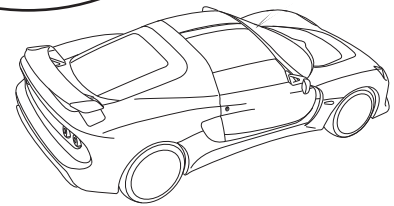

- Ensure that all electrical loads (e.g. lights) are switched off.
- If the car is fitted with security coded audio equipment, check that the code is available for entering after battery reconnection.
- Wait for at least **30 MINUTES** after switching off the ignition to allow the engine management system to adjust the setting of some components ready for re-starting.
- Note: Automatic models will default to P - Park if the battery is disconnected or becomes discharged
- Ensure the alarm is disarmed. If the battery is disconnected when armed, the alarm will be triggered.
- Disconnect the negative (earth; black; '-') battery cable first, and re-connect last.

**⚠ WARNING: If the battery positive terminal is inadvertently earthed (e.g. when using a spanner) whilst the negative terminal is still connected, the resultant short circuit, with heavy sparking and current flow, could cause serious burns and/or a fire.**

### Battery reconnection

Refit the battery, with the terminals outboard, by reversing the removal procedure. Remember to push on the breather pipe (if applicable), and note the polarity symbols marked on the battery case before reconnecting the battery cables as detailed below.

- vi. Check again that all electrical loads are switched off.
- vii. Connect the positive battery cable first, followed by the negative (earth) cable.
- viii. Be aware that the vehicle security alarm may be triggered by the action of battery re-connection. Have the alarm transmitter key ready to disarm the alarm (see 'Vehicle Security Alarm').
- ix. After reconnection, a change in the engine performance characteristics may be noted for a period whilst the computer controlled engine management system 're-learns' some of its settings.
- x. If necessary, enter the security code into audio equipment.



## Battery removal

Disconnect the battery terminals, see 'Disconnecting the Battery' and pull off the breather pipe (if applicable). Release the M6 x 16 hex flg, screw (2) securing the clamp bracket at the base of the battery, and manoeuvre the battery out of the luggage compartment.

**⚠ WARNING: When lifting the battery out of, or into the car, be aware of the considerable weight and take all appropriate precautions to safeguard personal health. Injury can result from improper lifting technique. Keep the battery upright, and protect from sharp knocks and shocks. The plastic case is easily damaged by careless handling.**

## Battery charging

Under conditions of normal daily use, it should not be necessary to use an external battery charger. In a low usage conditions, however, it is important to maintain the charge state of the battery using a trickle charger, or an automatic battery management conditioner such as that available through Lotus Dealers.

Note: A battery conditioner will maintain a fully charged battery, but cannot recharge if the battery becomes discharged. Starting difficulties may be encountered after an unattended period of 3 weeks. A battery conditioner is able to continuously monitor battery charge state and switch on and off automatically in order to maintain the battery in a fully charged condition without danger of damage through overcharging.

If the battery becomes discharged to the extent that the car cannot be started, the recommended course of action is to fit a substitute battery whilst the original battery is trickle charged. If, in an emergency, the car has to be 'jump' started, the subsequent conditions of car use may not allow for sufficient alternator charging of the battery to achieve a fully charged state.

The battery should be trickle charged by external means until 12.8 volts is recorded, this process may take 24 hours or longer. Putting the battery into service at a lower state of charge will reduce the time period for which the car can be parked without subsequent starting concerns. A battery left in a fully discharged state for a prolonged period, may not be recoverable to its original condition. A discharged battery is also vulnerable to freezing of the electrolyte, which could result in a damaged casing.

**⚠ WARNING: Hydrogen gases generated by the battery could cause an explosion, resulting in severe personal injuries. Charge the battery in a well ventilated area. Never charge a frozen battery. It may explode because of gas trapped in the ice. Allow a frozen battery to thaw out first. If you get electrolyte, which is an acid, in your eyes or on your skin, immediately rinse with cold water for several minutes and call a doctor.**

## 'Jump' Starting

### Auxiliary Power Posts

Access to the battery in the rear luggage compartment is available only after opening the engine cover lid/tailgate via the release handle on the cabin rear bulkhead.

If the car is centrally locked, and then the vehicle battery becomes discharged power must be restored before the doors may be opened and the battery accessed.

To facilitate the connection of an auxiliary power supply, a pair of secondary battery posts are provided at the left hand front of the car, beneath the front body access cover, see service notes section BT.2 for further information.

If the battery becomes discharged to the extent that the engine cannot be started, the recommended action is to remove the battery for bench charging, and/or fit a substitute battery until this process is complete.

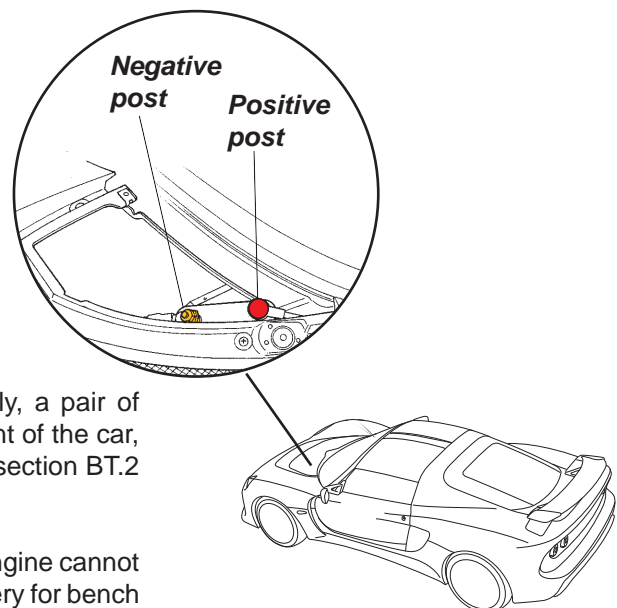



If this option is unavailable, the car may, in an emergency, be 'jump started' from a second vehicle with 12V negative earth electrics, but be aware that such a process can cause damage to vulnerable electronic controllers, which would not be covered by the New Vehicle Warranty.

**⚠ WARNING:** It is most important that the correct procedure is followed in order to reduce the risk of damage to either car's electrical system, and most importantly, to minimise the danger of a spark induced battery explosion. Check that the slave car also has a 12V NEGATIVE EARTH electrical system.

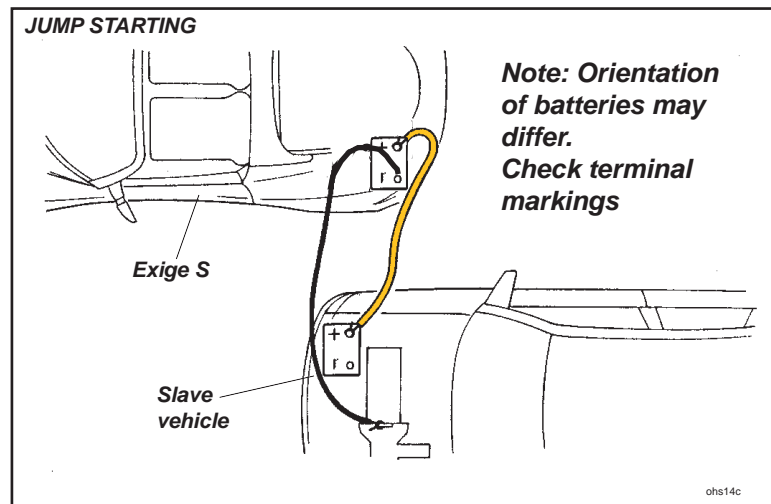

### 'Jump' Starting Procedure









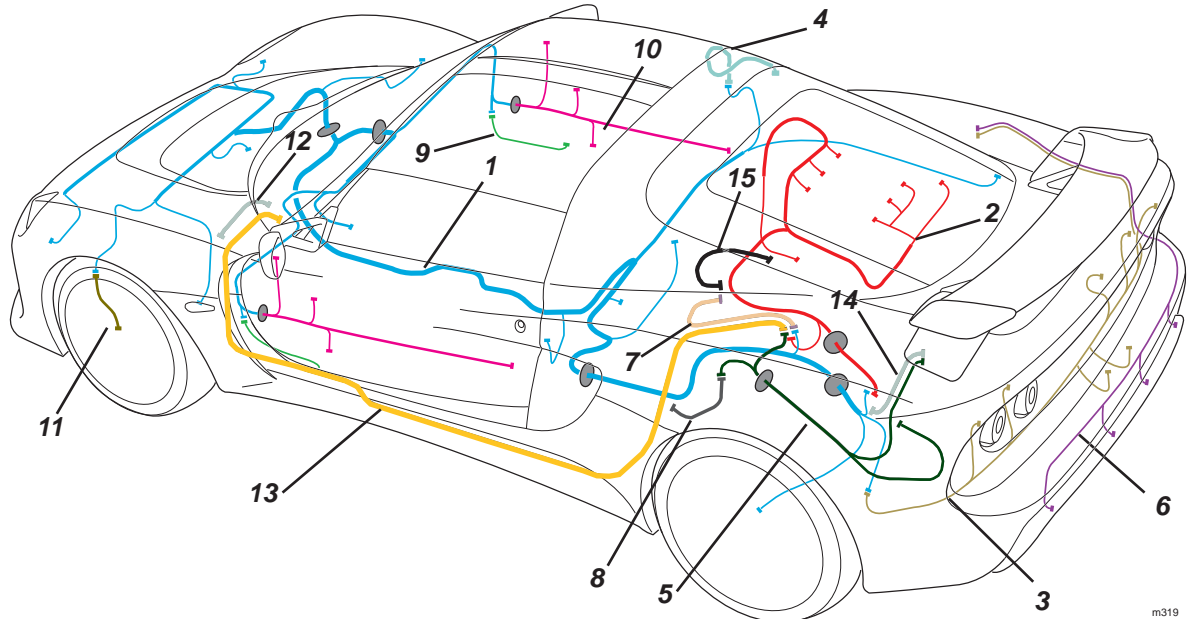





- With the engine of the slave car running at a fast idle, use one jumper cable (red) to connect the positive (+) terminal of one battery to the positive terminal of the other battery.
- Take care to avoid inadvertently earthing the free end of this cable to the metal body or chassis of either car.
- Connect one end of the other jumper cable (black) to the negative (-) terminal of the discharged battery.
- A spark will occur when the other end of this cable (the final connection) is connected to an earth on the slave car. This connection should therefore be made to an earthing point well away from the battery, and from any fuel vapour area or moving parts. An engine hanger bracket is often ideal.
- Start the disabled vehicle in the usual way, and run at a fast idle.
- A spark will occur at the first disconnection of a jumper cable, so it is essential that the first disconnection is made from the slave car earth. Both batteries (especially the discharged one) will be 'gassing' heavily at this time, and if the first disconnection is made at a battery terminal, there is a danger that the hydrogen gas may be ignited by the spark with a resultant explosion.
- Have the cause of the flat battery investigated and rectified, and trickle charge the battery as detailed above.

**⚠ WARNING:** Both the final connection and the first disconnection should be made away from the battery to reduce the risk of explosion. Causing an electrical short circuit could result in serious personal injury and/or vehicle damage. Use only jumper cables of adequate cross-section, fitted with completely insulated alligator clamps. The cables must be long enough to allow that neither cars nor cables touch each other.



MV.11 - HARNESS ROUTING



- |   |  |   |   |
|---|--|---|---|
|    | 1. Main harness                              |    | 9. Courtesy switch jumper harness                   |
|   | 2. Engine harness                            |   | 10. Door harness                                    |
|  | 3. Rear harness                              |  | 11. Wheel Speed Sensor extension lead               |
|  | 4. Tailgate harness                          |  | 12. CDL power up negative cable                     |
|  | 5. Battery harness                           |  | 13. Front positive stud to rear positive stud cable |
|  | 6. Parking aid harness                       |  | 14. ECU plate to battery negative cable             |
|  | 7. Rear positive stud to starter motor cable |  | 15. Engine to starter earth earth                   |
|  | 8. Gearbox to chassis earth cable            |   |   |

The main harness runs from the main fusebox/relay station at the passenger side of the front services compartment, and divides into three branches; one running forwards across the front of the chassis well to feed the interior fan motor, heater/a.c. functions, radiator fans and ABS controller, and then round the front of the crash structure to supply the horn and front lights. A second branch connects to the radiator fans

The third branch runs rearwards through the scuttle where it divides again to run across the dash top, picking up on the positive post, and supplying the instrument pack and switchgear and under dash relays.

The harness then runs along the cockpit centre tunnel to the rear of the cabin, over the top of the fuel tank bay, and through a grommet at the left hand rear corner of the cabin.

At the left hand front corner of the engine bay, one branch continues rearwards through a rear clamshell grommet to connect with the rear lighting harness, rear fusebox and engine ECU routed inside the clamshell.

Another branch runs across the engine bay/cabin bulkhead to the tailgate harness.

The same main vehicle harness is fitted to both RHD and LHD models, with the harness direction reversed at applicable areas to accommodate the connection of driver controls, instruments panels, fuse boxes, electronic throttles etc.

## Battery cables; positive & negative posts

1. Battery negative to ECU mounting plate earth earth cable.
2. Battery positive terminal to rear positive post cable.
3. Battery negative terminal to chassis rear earth point cable.
4. Rear positive binding post on underside of wheelarch panel.
5. Rear positive post to starter solenoid cable.
6. Rear positive post to front positive post cable (running along LH side chassis rail to binding post on scuttle).
7. Chassis earth to engine earth cable (bolted to transmission casing).
8. Main & start relay in rear fusebox feed cable.
9. Positive feed cable for selected mini fuses in rear fusebox.
10. Front positive binding post on scuttle (under dash top fascia panel).
11. Chassis front earth mounting stud located on inner chassis in HVAC climate chamber.
12. Ignition switch positive cable and M1/M2 maxi fuse feeds in main fusebox.
13. Positive feed cable for selected fuses in main fusebox.

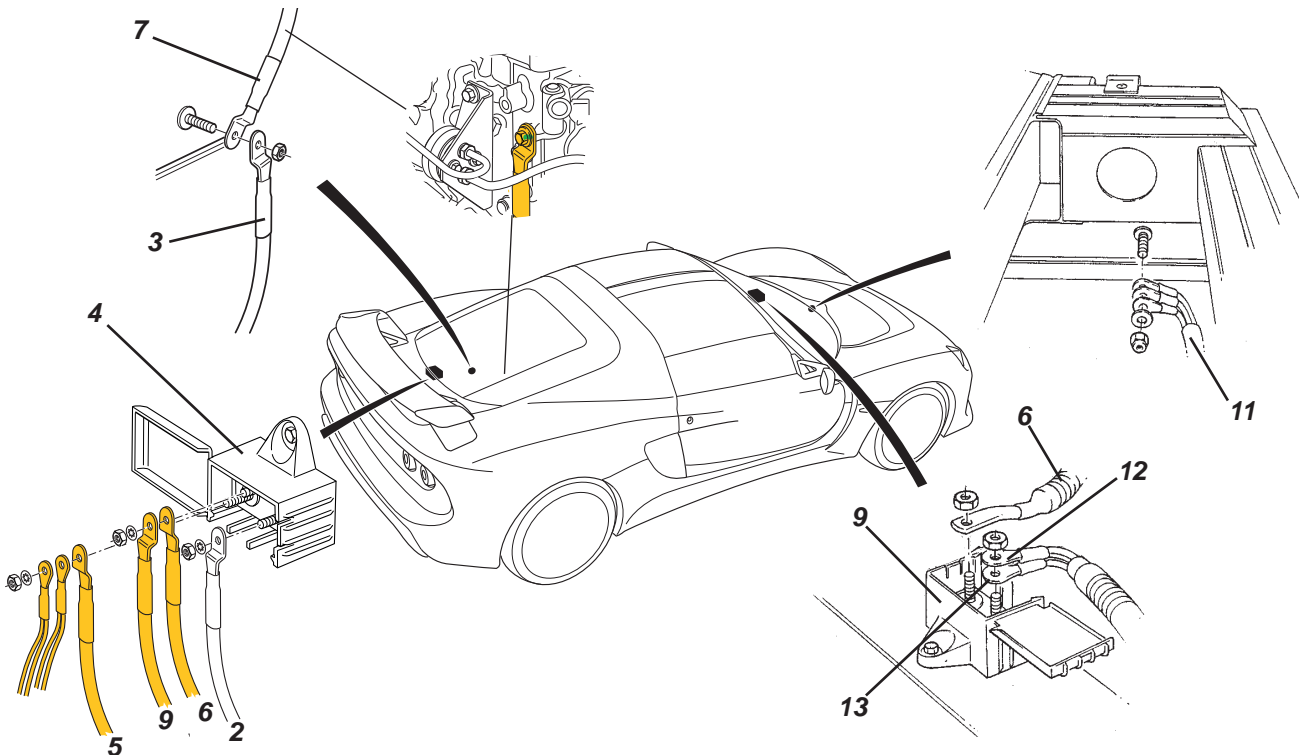
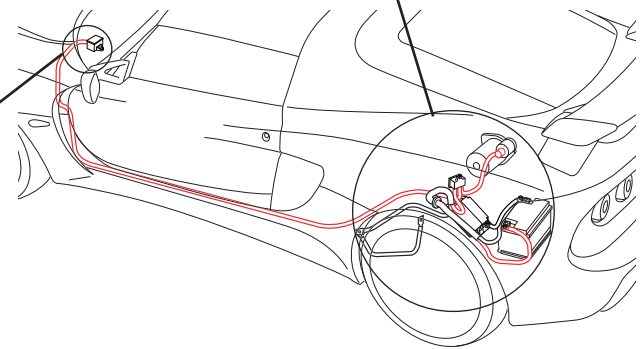
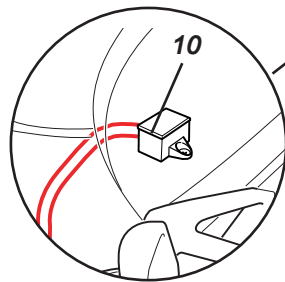
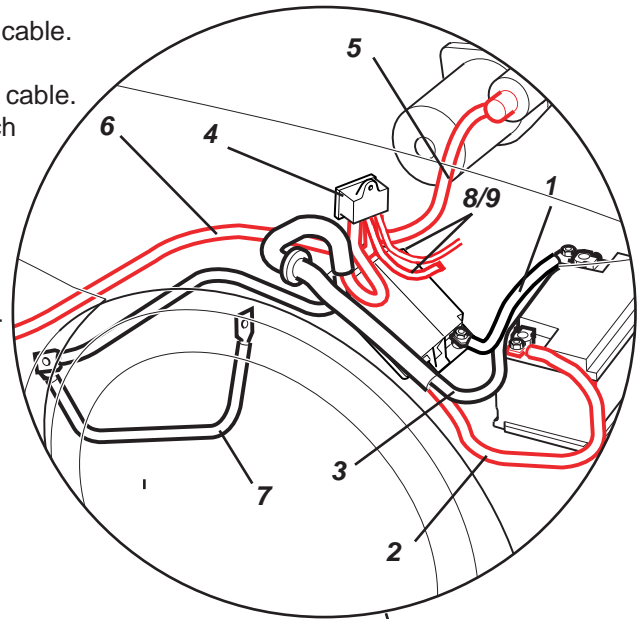

**Battery positive cables**

The main battery positive cable runs from the battery and is fixed to one of the three studs fitted to the binding post which is mounted on the underside of the LHR wheelarch panel,

The three binding post studs are attached to a common single plate, allowing any cables attached to any of the three studs to draw current from the battery.

**Binding post power distribution***Outboard stud*

Main positive cable from battery

*Central stud*

Rear positive post to front positive post cable (running along LH side chassis rail to binding post on scuttle).  
Feed cables for main & start relays in rear fusebox.

*Inboard stud*

Starter motor cable

Positive feed cables for selected mini fuses in rear fusebox.

**Binding post**

The binding post studs/plate are contained within a plastic housing which has an integral mounting hole allowing it to be fixed to a stud bonded onto the underside of the boot box panel.

Access to the binding post requires the removal of the LHR wheelarch liner; refer to service notes section BT.5 for further information.

*Cable access/removal***Preparation:**

To ensure that there is no possibility of inadvertently earthing any of the positive cables whilst carrying out the procedure shown below, disconnect the vehicle battery, ensuring 30 minutes have elapsed since removing keys from ignition switch; refer to sub-section MV.10 for further information.

*Removal:*

Unclip the cover of the positive binding post to access the 6 cable eyelets and M8 fixing nuts.

Release the M8 nut(s) securing the cable(s) eyelet to the post stud(s) as required and remove the cable from the binding post stud.

*Refitment:*

Is the reverse of removal except

Once refitted, check the alignment of the cables ensuring that they are not kinked or fouling on any body panels or ancillary components

Refit the M8 securing nut(s) on the post stud(s) and torque tighten to 11Nm

Apply anti-corrosion compound to the nuts and threads of the 3 positive post studs.

Refit the binding post cover

**Important Note**

If 2 cables are secured to the same positive post stud, ensure that their cable eyelets are placed 'back to back' to ensure correct harness to post stud clamping is achieved.

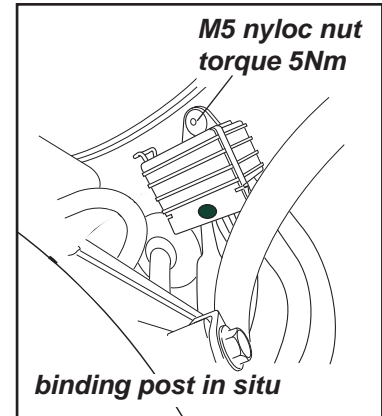

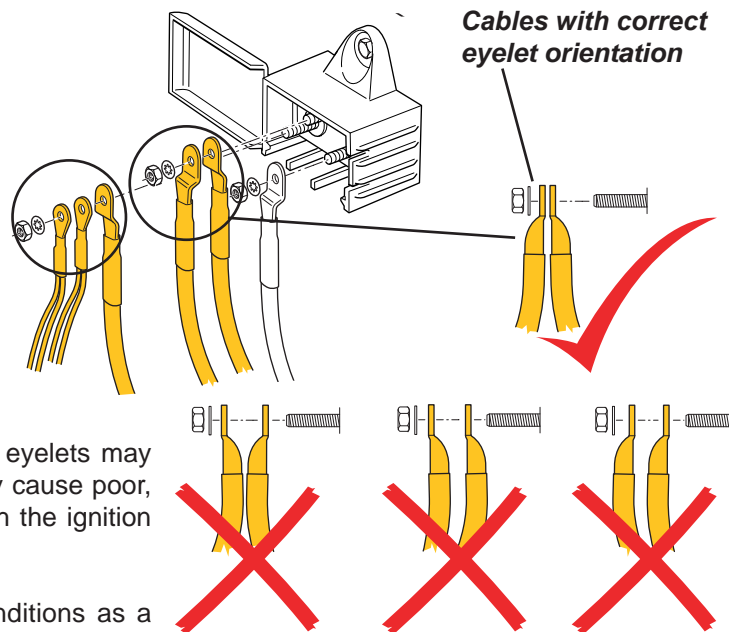

Incorrect orientation of adjoining power cable eyelets may result in insecure cable attachment which may cause poor, non-start or the engine failing to turn-over with the ignition key.

These concerns may duplicate the same conditions as a disconnected battery therefore not generating any fault codes that could assist with any fault finding diagnosis.

### Battery negative cables

2 earth cables connect to the battery earth terminal, one connects to a binding post mounted on the engine ECU plate, the other to a chassis earth point on the inside surface of the LH chassis rail at the side of the engine bay, accessible from beneath.

From here, an earth braid connects the transmission casing to provide engine earthing, (also see illustrations on previous page).

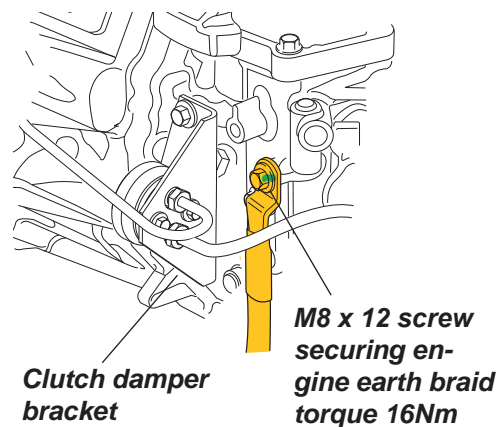

A second earth point is used at the front of the chassis to provide for front mounted components, and is located within the front services compartment on the inside surface of the chassis LH siderail, (see illustrations on previous page). Each chassis earth point uses an M8 threaded insert and on some cars, a special stepped washer which must be fitted the correct way round in order to contact the chassis (anodisation removed around insert).

The chassis and cable earth terminals should be coated with an anti-corrosion compound.

The engine earth braid is mounted vertically downwards from its eyelet and is fixed to the transmission case adjacent the clutch damper bracket by an M8 x 12 screw and washer securing torqued to 16Nm.



MV.12 - FUSE & RELAY STATION LOCATIONS, FUSE RATINGS, INERTIA SWITCH & SWITCH PACK

**Main Fusebox - Manual Vehicles**

The main fusebox is located in the front services compartment on the passenger side and is an integral part of the main harness. The fuse box contains 40 'mini' and 2 'maxi' type fuses which are numbered and coloured according to their amperage rating, and may be pulled out from their slots using the fuse extractor tool provided on the fusebox lid. Relays for specific vehicle electrical services are also contained within the fuse box

For access, remove the front body access panel, see service notes section BT.2 for further details and unclip the fusebox lid.

Slot	Rate	Circuit
1.	10A	Ignition services
2.	10A	ABS
3.	10A	Stop lamps
4.		Spare
5.	2A	Parking sensor buzzer
6.	20A	Driver's window motor
7.	20A	Pass. window motor
8.	7.5A	Direction indicators
9.	5A	Day time running lamps
10.		Spare
11.	15A	Wiper motor
12.	20A*	Interior fan
13.		Spare
14.	2A	USB charge connector
15.	7.5A	Radio/Instrument pnl. key in
16.	3A	ECU/start, fuel pump & HRS relays
17.	5A	Reverse lamp/parking snsrs.
18.		Spare
19.	5A	Alternator ign
20.	7.5A	AC clutch
21.	10A	Sidelamp/rear fog lamp
22.	10A	LH dip beam
23.	10A	RH dip beam
24.	15A	LH main beam
25.	15A	RH main beam
26.		Spare
27.	20A	Rad fan 2 fast
28.	20A	Rad fans 1&2 slow/fan1 fast
29.	20A	Sec rad fan
30.		Spare
31.	7.5A	Horn
32.	15A	Hazards
33.	20A	Aux power socket
34.	7.5A	CDL
35.	5A	OBD
36.	7.5A	Radio / switch pack module
37.	10A	Alarm & interior lamp
38.	7.5A	Instrument pnl. h/lamp flash
39.		Spare
40.		Spare
M1	40A	ABS main power 1
M2	25A	ABS main power 2

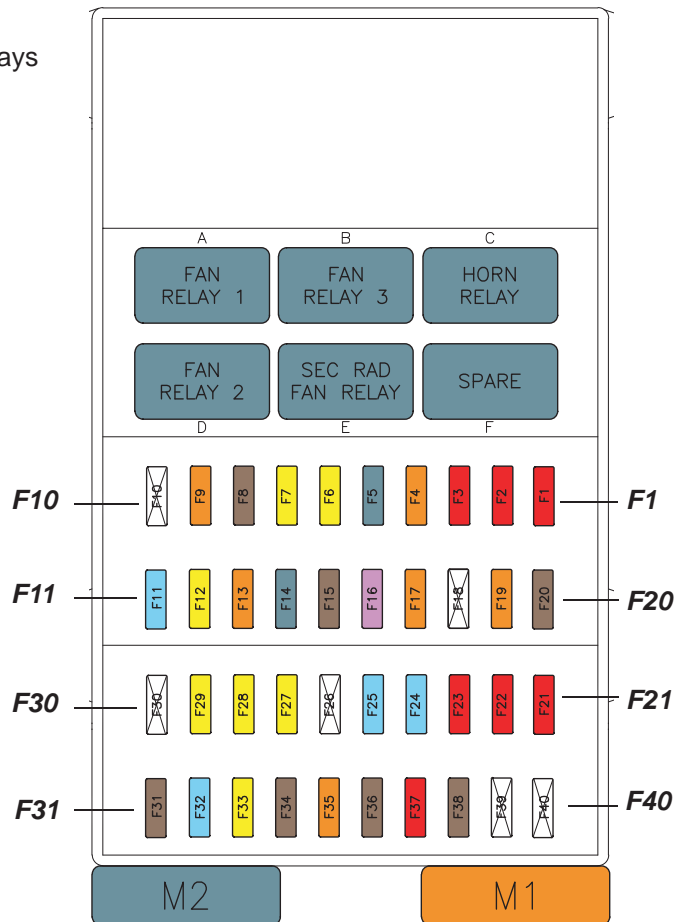
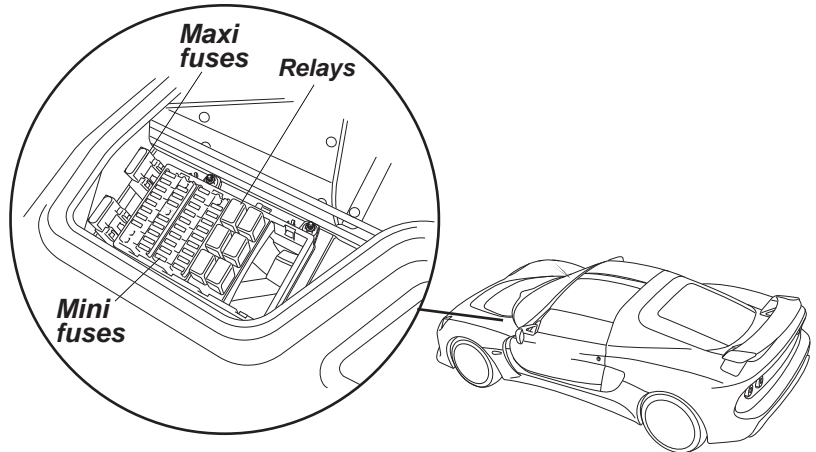

\*25A used on GCC cars fitted with auxillary HVAC unit





Main Fusebox - Automatic Vehicles

Slot	Rate	Circuit
1	10A	Ignition services
2	10A	ABS
3	10A	Stop lamps
4	3A	Rear ignition relay
5	20A	Driver's window motor
6	20A	Passenger's window motor
7	7.5A	Direction indicators
8	5A	Day time running lamps
9	2A	USB charge connector
10	7.5A	Radio/Instrument pnl. key in
11	10A	Sidelamp/rear fog lamp
12	10A	LH dip beam
13	10A	RH dip beam
14	15A	LH main beam
15	15A	RH main beam
16	7.5A	Central door locking
17	5A	OBD
18	7.5A	Radio / switch pack module
19	10A	Alarm
20	7.5A	IC/Headlamp flash
21	15A	Wiper motor
22	20A	Interior fan
23	7.5A	Horn
24	15A	Hazards
25		Spare
26		Spare
27		Spare
28		Spare

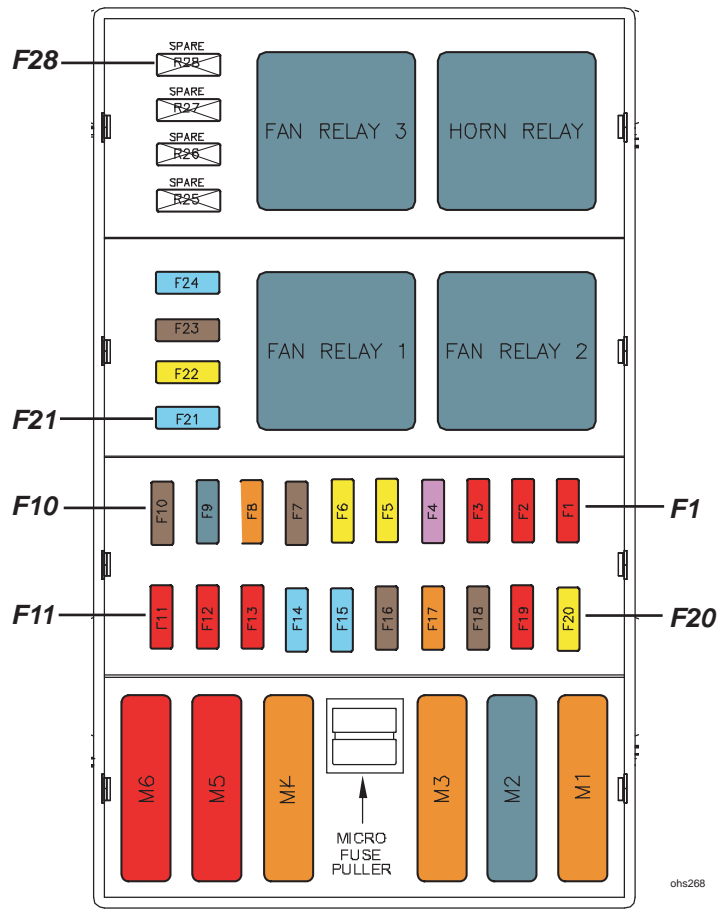

M1	40A	ABS main power 1
M2	25A	ABS main power 2
M3	40A	Cooling fan 2
M4	40A	Cooling fan 1
M5	50A	Battery services
M6	50A	Ignition services

ohs268

**Fuse box re-positioning**

Note: Fuse box removal from the vehicle is impractical as it is integral to the main vehicle harness.

Certain repair operations such as windscreen wiper motor and HVAC module investigation/removal will require the fuse box to be re-positioned to gain sufficient access.

The main fusebox casing is retained within a bracket, which in turn, is secured to the windscreen frame and windscreen wiper mounting bracket.

**Fuse box bracket***Removal:*

Release the M8 x 20 screws (2) securing the front fuse box bracket to the windscreen wiper mounting frame.

Release the M6 x 16 screws (2) securing the fuse box bracket to the windscreen frame.

Carefully lift the fuse box with bracket assembly and place to one side ensuring that no unnecessary strain is placed on the wiring harness or connections.

*Refitment:*

Is the reverse procedure of removal.

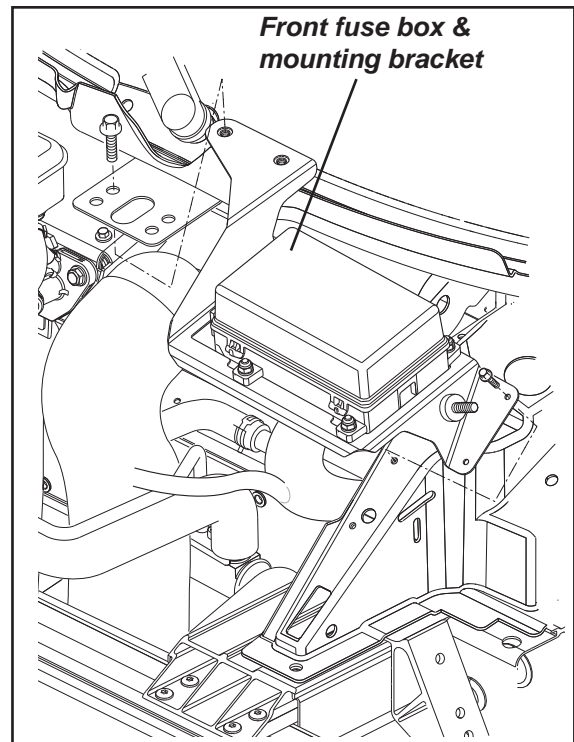



**Rear Luggage Compartment Fusebox - Manual Vehicles**

Additional fuses and relays are located at the left hand of the rear luggage compartment next to battery and is an integral part of the main harness.

To gain access, remove the left hand storage compartment trim panel by pulling it away from the luggage compartment releasing it from its velcro fixings.

The fuse box contains 'mini' type fuses as well as relays for specific vehicle electrical services. The fuses may be pulled out from their slots using the fuse extractor tool provided on the fusebox lid.

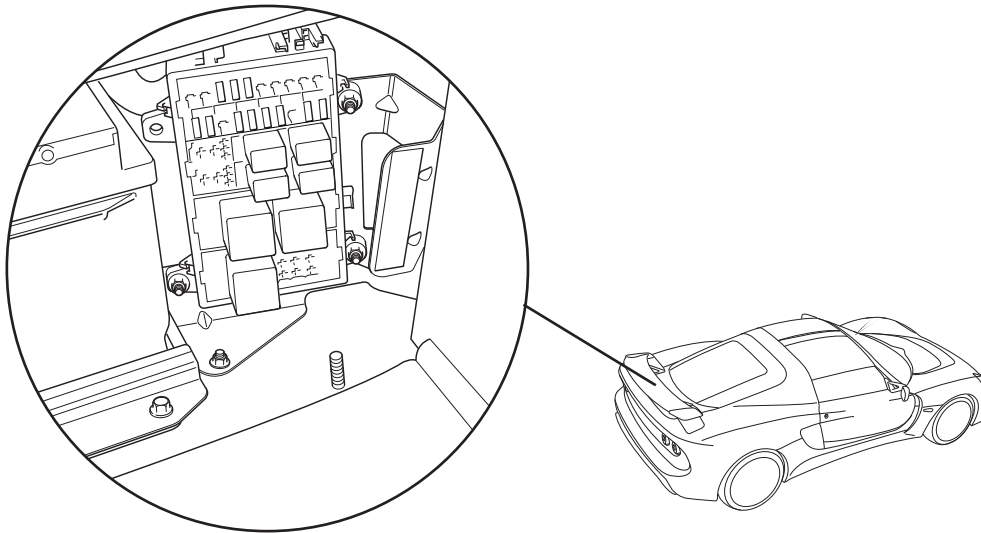

Slot	Rate	Circuit
1	20A	Fuel pump
2	5A	Alternator sense
3		Spare
4	5A	HRS SW LED
5	2A	Hot soak pump
6	7.5A	O2 heaters
7	7.5A	VIM, VVT, PURGE, ACIS, CVCV, A/C VALVE
8		Spare
9	10A	Coils
10	10A	INJ'S / ECU PWR Fan relays, HTD seat relays
11		Spare
12		Spare
13		Spare
14		Spare
15		Spare
16	10A	LH heated seat
17	10A	RH heated seat
18	20A	HRS
19		Spare
20		Spare

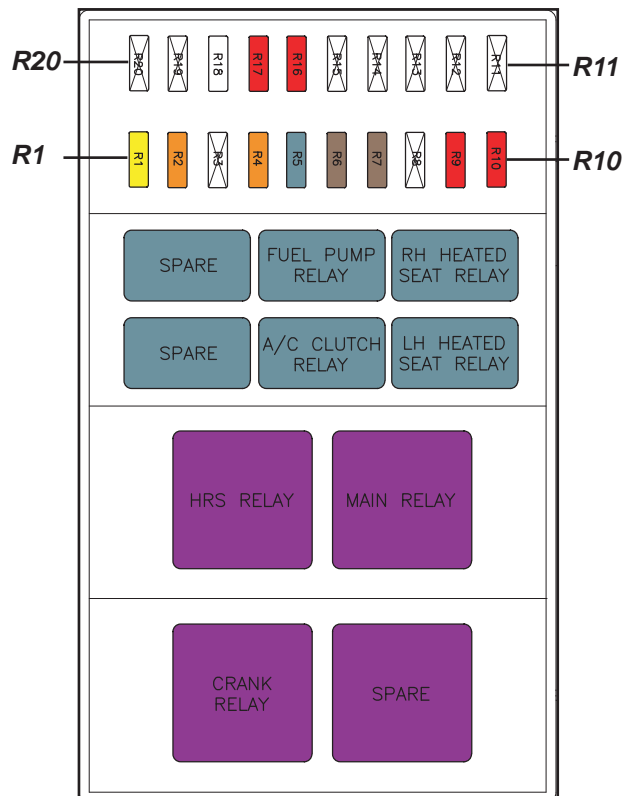



Rear Luggage Compartment Fusebox - Automatic Vehicles

Slot	Rate	Circuit
1	20A	Fuel pump
2	5A	Alternator sense
3	20A	Auxillary power socket
4	5A	HRS SW LED
5	2A	Hot soak pump
6	7.5A	O2 heaters
7	7.5A	VIM, VVT, PURGE, ACIS, CVCV, A/C VALVE
8	7.5A	Engine ACC solenoids (Auto only)
9	10A	Coils
10	10A	INJ'S / ECU PWR Fan relays, HTD seat relays
11		Spare
12		Spare
13		Spare
14		Spare
15	TBC	Water valve (GCC vehicles only)
16	3A	ECU, F.P Relay (Auto only)
17	5A	Reverse lamps
18	2A	Reverse buzzer
19	5A	Alternator
20	7.5A	A/C clutch
21	10A	LH heated seat
22	10A	RH heated seat
23	20A	HRS
24		Spare
25	30A	TCU (Auto only)
26	5A	Gear lock solenoid (Auto only)
27		Spare
28		Spare

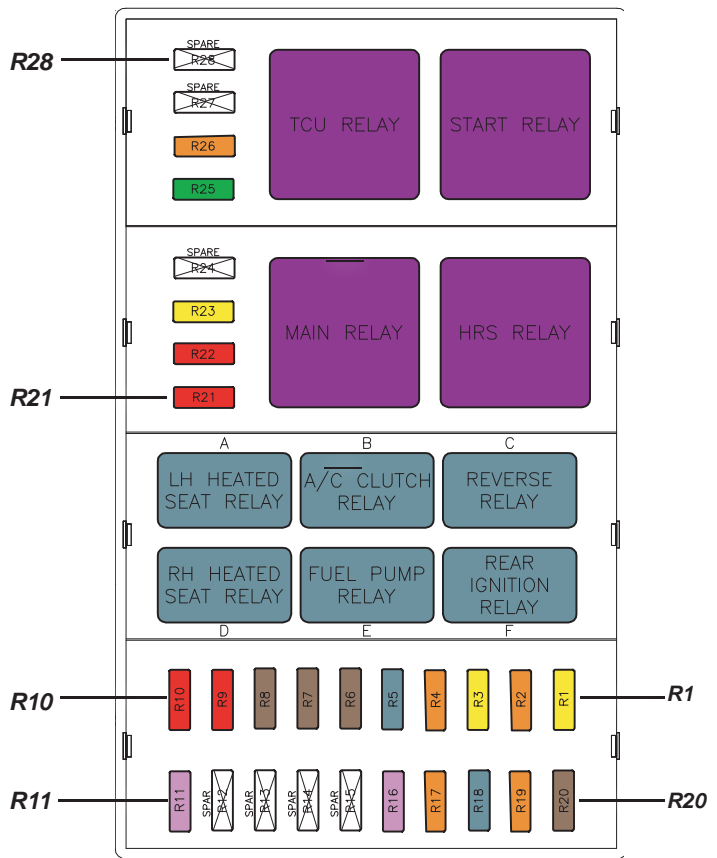

**Fuse box re-positioning**

Apart from fuse/relay removal or refitment it is not normally necessary to disturb the rear fusebox assembly.

Only repair operations requiring the removal of the rear clamshell will require the fuse box to be re-positioned to allow the main harness to be withdrawn from the luggage compartment area.

The rear fusebox consists of separate plastic terminal block housings to locate relevant circuit fuses and relays. Integral slots at the sides of the block housings locate them into a plastic frame which is in turn, secured to a bracket fixed to the luggage compartment floor panel.

The terminal block/frame assembly cannot pass through the clamshell aperture as one piece but must be partially dismantled to allow the individual housing blocks to be fed through from the luggage compartment to the engine bay.

**Dismantling procedure:**

1. Release the M6 screws securing the fusebox frame to the luggage bay bracket.
2. Carefully pull the fusebox forward withdrawing it away from the bracket retaining studs.
3. Unclip the housing blocks from the frame.
4. Taking great care not to place undue strain on the harness wiring or connections to the fusebox, feed the individual housing blocks/main harness grommet through the luggage compartment aperture into the engine bay, positioning safely away from any heat, grease, oil contamination or sharp edges.

**Refitting procedure:**

Is the reverse of removal.

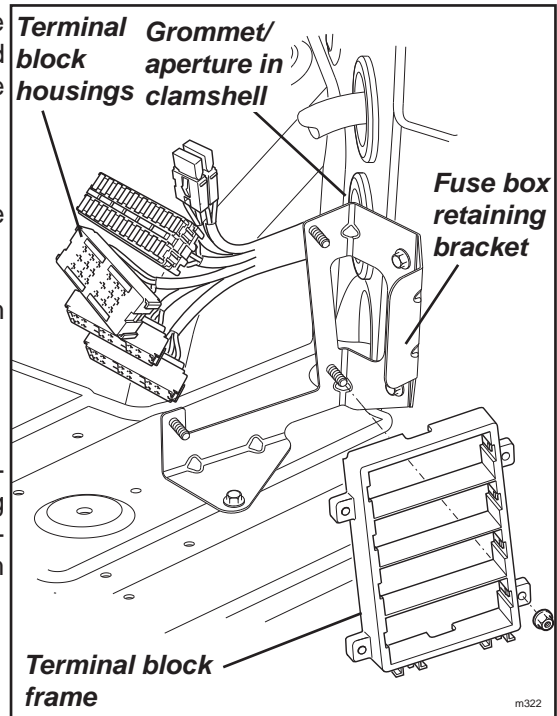
**Footwell sited relays**

A wiper motor module relay and turn/hazard relay are secured to the main wiring harness just ahead of the scuttle beam and accessible from the passenger footwell.

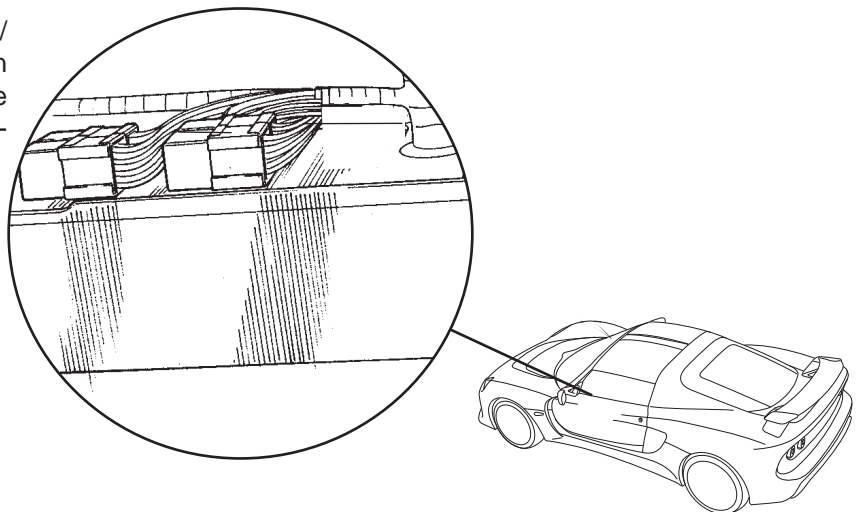



**Safety inertia switch**

The safety inertia switch is designed to operate on impact, typified by vehicle collision, to switch off the fuel pump, and thus minimise any fire hazard. The central door locking will also be triggered to unlock the doors.

The inertia switch is mounted at the right hand of the engine bay on the rear subframe in front of the engine and inboard of the rear body panel. Although accessible it is not highly visible so it may be necessary to use a torch to locate it. The switch is reset by pressing the rubber diaphragm button on the top of the unit.

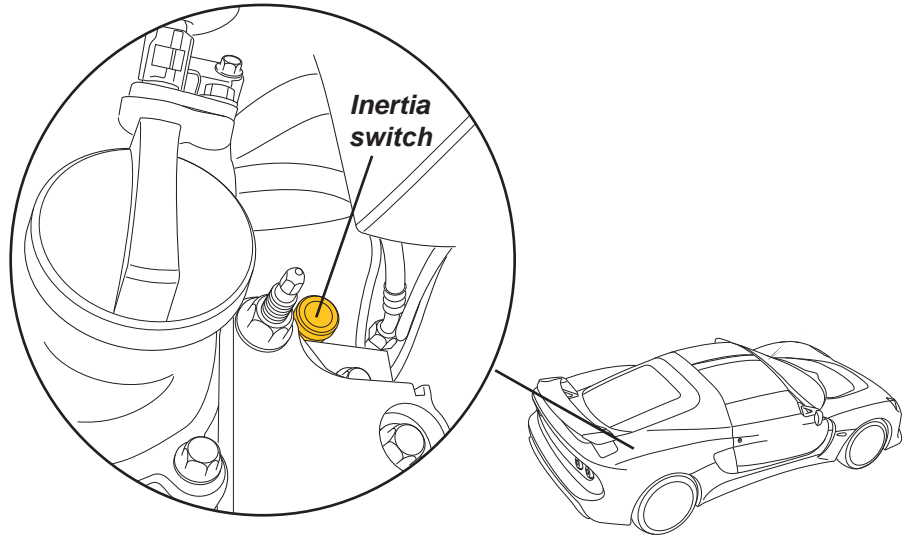



**Switch pack module**

Many driver operated controls are activated by 'momentary'\* type switch buttons. When depressed they switch the applicable relay(s) located within the fuse boxes or their relevant control modules to activate/de-activate the vehicle function selected.

*\*A momentary type switch is only engaged whilst it is being depressed, as opposed to a typical "on/off" switch, which latches in its set position.*

External light and HVAC (Heating Ventilation & Air Conditioning) switches are also operated by momentary type push button switches with their operating functionality being controlled by the switch pack module located underneath the dashboard panel, behind the instrument panel.

**Removal:**

If the fascia top panel has not been removed for any other repair then the switch pack can be accessed for diagnosis or replacement by removing the instrument panel, see sub-section MV.5 for further information.

Once the instrument panel has been removed the switch pack can be withdrawn from the dashboard by releasing the M4 x 12 pan head screws and washers (2) securing it to the chassis scuttle panel.

**Refitment:**

Is the reverse of removal.

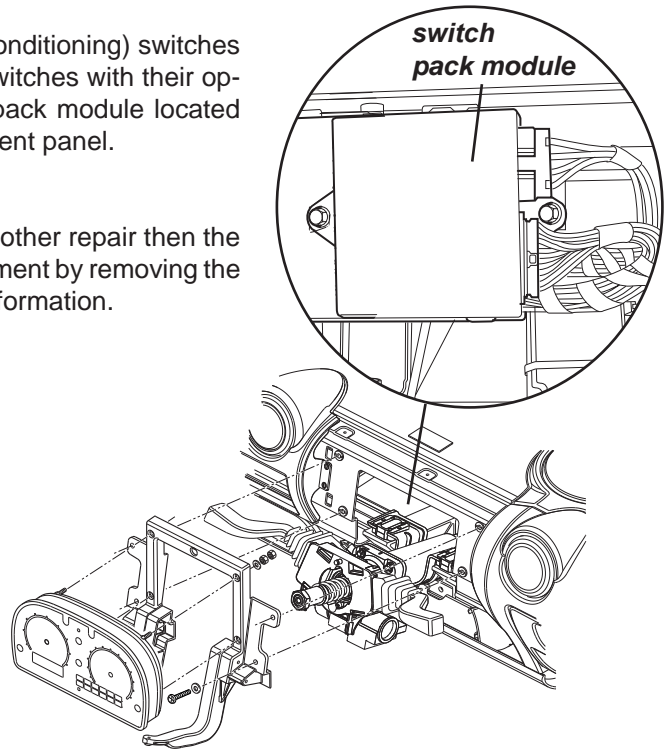

**Harness connection and 'Pin out' identification**

The switch pack is connected to the main vehicle harness by 2 connector blocks. Connector block 'A' which has 26 terminal pin outs and connector block 'B' which has 16 terminal pin outs.

The terminal pin outs are not identified on the actual unit but are referred in the relevant service note circuit diagrams as:

Connector block 'A' - SPMC2 (Pin outs 1 - 26)

Connector block 'B' - SPMC1 (Pin outs 1 - 16)

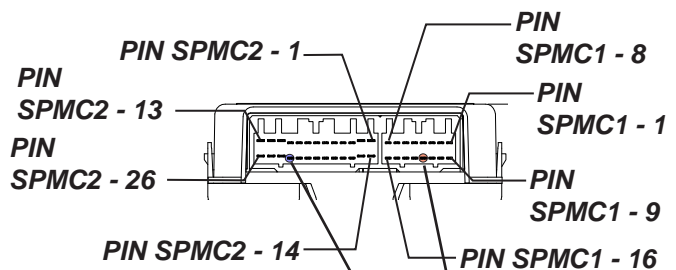

**Example of EMS pin information as displayed in an Exige S Circuit Diagram**

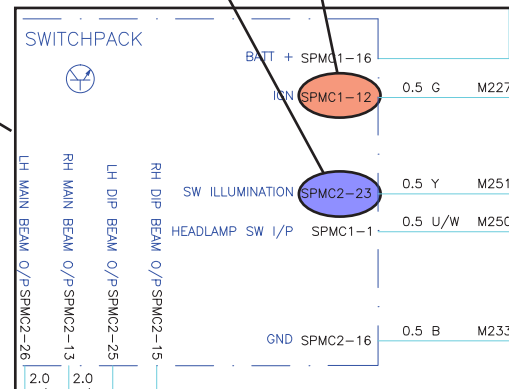



MV.13 - REVERSE PARK SENSOR SYSTEM (if fitted)

Operating principle

When reverse gear is selected the 4 ultrasonic sensors fitted within the rear diffuser trim will detect any potential objects that are within a 1.5 metre range of the rear of the vehicle.

The driver is alerted to any potential objects and their proximity to the rear of the vehicle by the frequency of the audible beep produced by a sounder (located behind the rear bulkhead trim panel) which increases in frequency as the distance to the object is reduced, becoming a continuous tone at approximately 300mm.

The reverse parking aid system comprises of the following major components:

- Rear parking sensors (4)
- Parking sensor to ECU harness
- Parking aid ECU
- ECU bracket
- Parking aid sounder

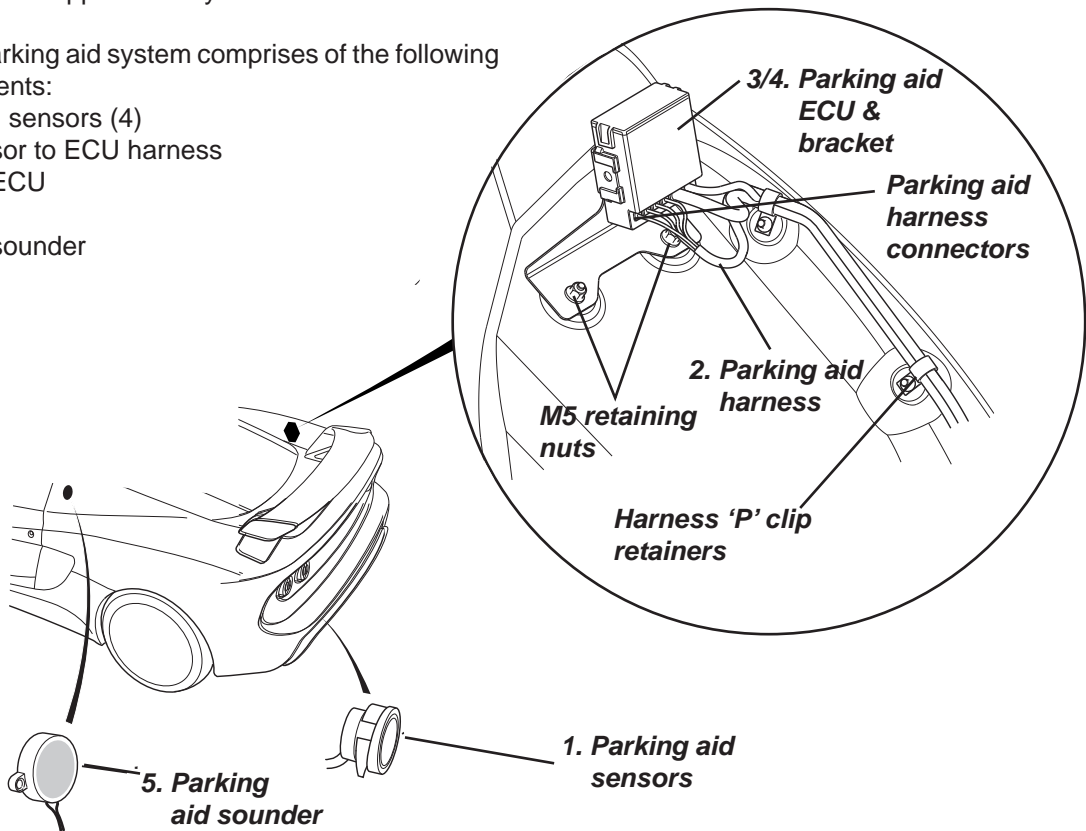
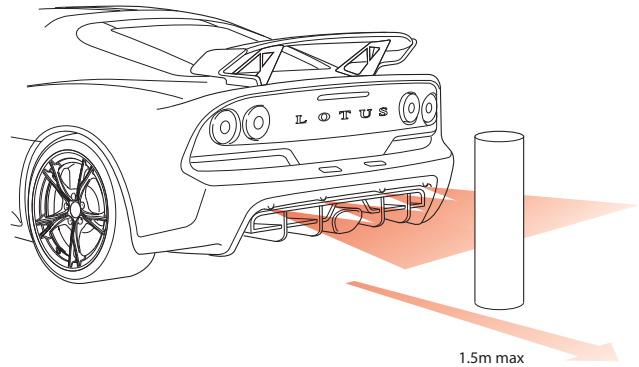

Each parking sensor consists of an ultrasonic proximity detector fitted within a black coloured protective housings which are pushed into apertures machined in the rear diffuser housing.

Each sensor is connected to its correspondingly labelled parking aid harness connector plug labelled (1 - 4).

Viewed from the rear of the vehicle, sensor 1 is fitted to the outboard LHS diffuser aperture, through to sensor 4 fitted to the RHS outboard aperture.

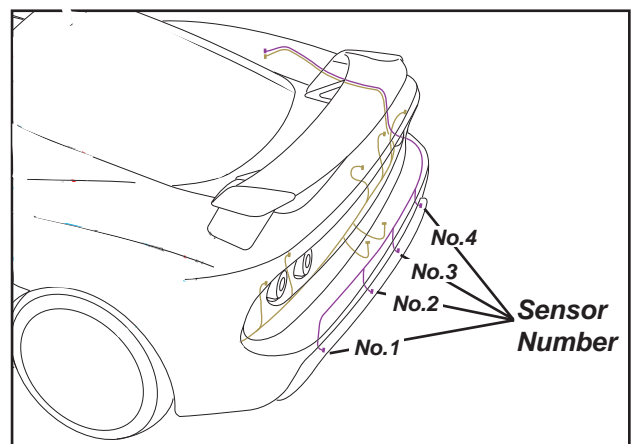





A small keyway is machined at the top of each sensor aperture which corresponds to the sensors locating tab which ensures it is mounted to its correct orientation within the diffuser trim.

When mounted to the correct orientation the small spot moulded on the sensor should be positioned vertically upwards.

The parking aid harness is fitted to the underside of the clamshell and routed behind the diffuser trim and retained with panel mounted edge clips. The harness enters the luggage compartment from the underneath of the RH side of the boot box panel.

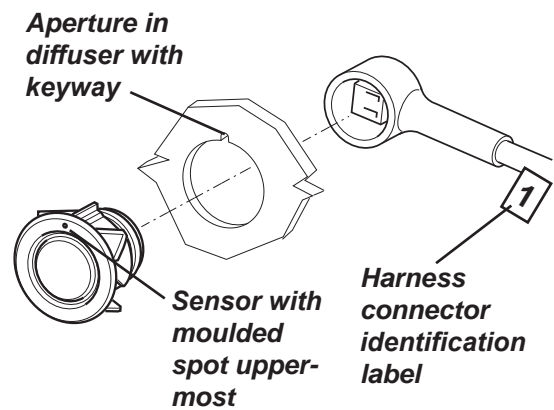

Once inside the luggage compartment area, it is secured to 'P' clips along with the rear vehicle harness, it then branches off into its 4 individual parking sensor harnesses/2 way connectors which can be identified by their number labels (1 - 4) which are taped to the 4 individual main core wires in the harness.

*Parking aid ECU removal:*

1. Carefully pull back the boot carpet from the RHR wheelarch area, taking care not to damage the carpet when passing it over tyre weld canister bracket.
2. The parking module/bracket and wiring are now visible, but do **NOT** attempt to remove the harness connectors whilst the module is still attached to clamshell.
3. Unclip the parking sensor and rear harnesses from the two 'P' clips securing them to the inner wheelarch panel.
4. Release the M5 nyloc nuts (2) securing the module bracket to the wheelarch.

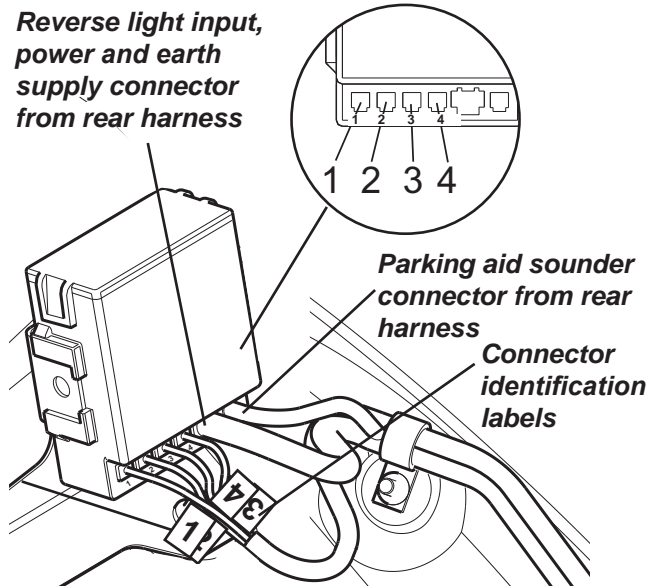

5. With the parking sensor and rear harnesses still connected to the module, lift the complete assembly off of the 2 M5 retaining studs (fixed to the wheelarch) and place it into the boot area.

6. The 4 parking sensor black 2 way connectors can be identified by their number labels (1 - 4) which are taped to the 4 individual main core wires in the harness.

7. Use a small pair of long nose pliers to ease the connectors from the module one at a time. **DO NOT** pull on the wiring harness.

Once all harness connectors are unplugged, the ECU can be withdrawn from the vehicle.

*Refitment:*

Is the reverse of removal

Refit the connectors to the module in the correct order, i.e., with the number label on the harness corresponding to the molded number on the module housing.

**NOTE:** Failure to connect the sensor harnesses correctly could result in inaccurate/misleading readings being produced by the ultrasonic sensors.



### Parking aid sounder

*Removal:*

The sounder is attached to the LH inboard side bulkhead panel by double sided tape.

Removal of the rear bulkhead trim panel is required to gain access to the sounder; refer to service notes section VE.11 for further information.

Gently pull the sounder away from the bulkhead/double sided tape and disconnect sounder flylead from the main harness connector plug.

*Refitment:*

A new piece of double sided tape will be required to adhere it back onto the panel.

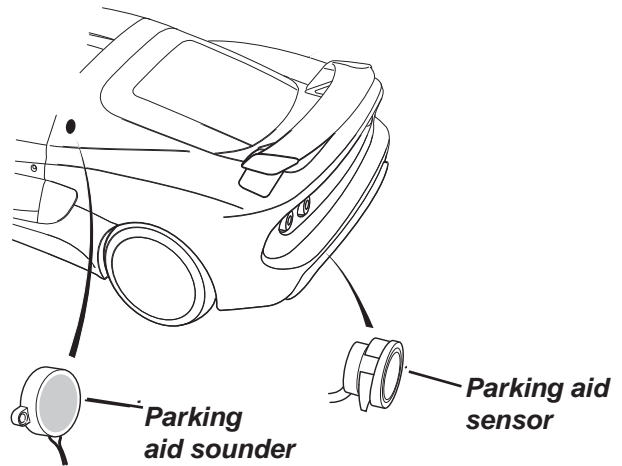

The bond area of the bulkhead panel should be cleaned with a dampened Scotchbrite pad and acetone solution to ensure an adequate abrasion of the bond path, then using paper sufficiently dampened with acetone, wipe residue from panel & then dry wipe with clean paper.

Apply new double sided tape to the panel and refit the sounder.

### Parking aid sensor

*Removal:*

The sensors are fitted with profiled retention clips which are designed to fold inwards whilst being pushed through the diffuser apertures and spring outwards once positioned behind the trim.

This means that removing the sensors by attempting to prise them away from the diffuser panel will result in damage to both the sensor and the panel.

The sensors clips must be folded inwards from behind the diffuser to ensure that no tool marks are made on panel.

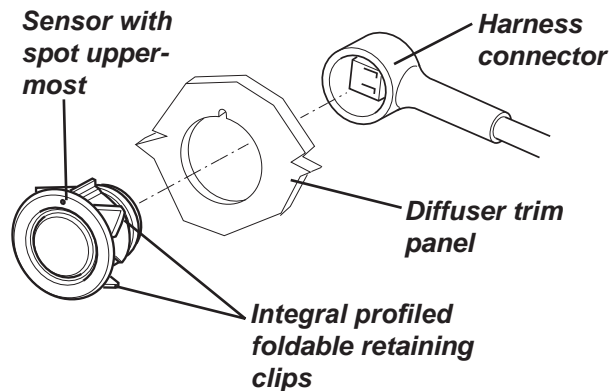

Note: Unless great care is taken the sensors cannot be removed without damaging their integral retaining clips.

*Refitting:*

Connect the parking harness connector to the terminal at the back of the sensor.

Ensuring the moulded spot on the sensor face is vertically uppermost, push the sensor back into the diffuser panel.

If all other components for the parking aid system are connected, test the system is now operating correctly.



## MV.14 - ECM (ELECTRONIC CONTROL MODULE) AND TCU (TRANSMISSION CONTROL UNIT)

The T6 Electronic Control Modules (ECM) & Transmission Control Unit (TCU)\* are non serviceable units incorporating microprocessors which process the inputs in real time, not only from the engine management sensors and internal transmission modules but various other sensors and modules within the vehicle such as the instrument pack, alarm system, Anti Lock Braking system (ABS) and Tyre Pressure Monitoring System (TPMS if fitted) etc.

*\*TCU only fitted to automatic transmission models.*

### **Firmware and calibration**

At the time of assembly the vehicles ECM & TCU (if fitted) are downloaded with the relevant firmware and calibration also referred to as its EMS programme or .CRP file. This ensures that the functionality of the ECM/TCU is correct in relation to its model, model year and the territory the vehicle is being sold into.

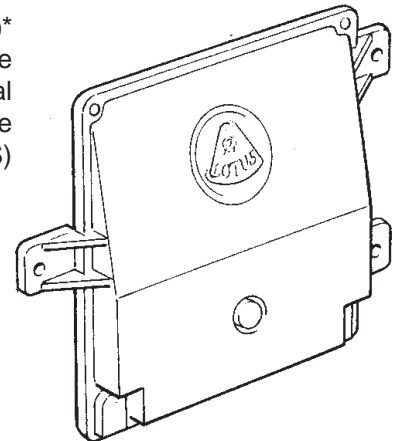

**ECM - Electronic Control Module  
(TCU similar)**

### **Vehicle configuration and variant code**

The ECM is then 'configured' dependant on the additional options that the vehicle should be equipped with such as but not limited to fitment of such items as:

- Sports, Race and Launch Mode options
- Tyre pressure Monitoring System (TPMS) if fitted
- Heated front seats
- Reverse park sensor
- Speed Alert Buzzer (GCC cars only)
- 'S' or Roadster body options
- Manual or automatic transmission

The selection of the relevant options will produce a 'variant code' for the vehicle which can be viewed in the EMS vehicle configuration screen using Lotus TechCentre and is also stored in the vehicles build book stored at Lotus Cars. At this time a self adhesive label is also attached to the casing of the ECM. The label displays an actual label part number and homologation number which will identify the ECM assembly in relation to:

- Model Year
- Engine type, induction system and power output
- Designated vehicle territory
- Calibration number
- Vehicle designation i.e., Elise, Evora etc

### **ECM protection**

*EMS programme:* To protect the ECM from subsequent incorrect programming which could cause poor, nonstarting or engine performance issues etc, the EMS programme initially downloaded at the factory cannot be overwritten with any other programme. The only EMS reprogramming possible is to update the 'level' of the existing programme already installed in the ECM.

In the event that the EMS programme downloaded into the ECM that does not match its existing programme then the vehicle will fail to start, the (Malfunction Indicator Light) MIL will illuminate and a fault code will be stored in the ECM.

*Variant code:* (Also see Technical Service Bulletin TSB 2012/17) new functionality for Lotus TechCentre was introduced from version V4.16.00 in November 2012 to prevent unauthorised variant code alteration in relation to:

- Exige S: Launch mode race mode (so that these options cannot be altered from the original production specification).
- Exige Roadster: Speed limiter (ensuring that maximum vehicle speed is limited for soft top models).



The current release of Techcentre will look for the three data bits in the variant code data string to be set to a certain value to then ask for the pass code function from Lotus. These three functions are as follows:

- Race Mode -True
- Launch Mode -True
- Speed Limiter -False

At the time of first issue of Service Note section MV, Lotus TechCentre will not allow the user to input any of these options into the existing Exige S/Roadster ECU without a pass code from Lotus Cars Aftersales.

If it becomes necessary to renew the ECU then use LSL618 Exige S Pre-Variant Coded ECM Order Form as shown in Lotus Technical Service Bulletin TSB 2013/01, so that you receive a pre-programmed/variant coded ECU for the vehicle.

If for any reason an existing ECM losses its existing variant code then contact your nominated FSE for further information (Note - this may require Lotus TechCentre to be connected to the vehicle at the time of contact to obtain specific ECM information).

**ECM Harness connection and 'Pin out' identification**

The ECM uses 3 harness connector blocks. The engine harness has 2 multi-plug connectors which connect to the central and left blocks (as viewed with the ECM in situ), with the vehicles main harness multi-plug connecting to the right block (as viewed in situ). All harness connection information to the ECM is identified on the relevant circuit diagrams by:

Block: L – Left, C – Centre and R – Right

Row: 1 – 4

Column: A – M (Note: The letter 'I' is not used, therefore A - M comprises of only 12 columns in the centre and right blocks).

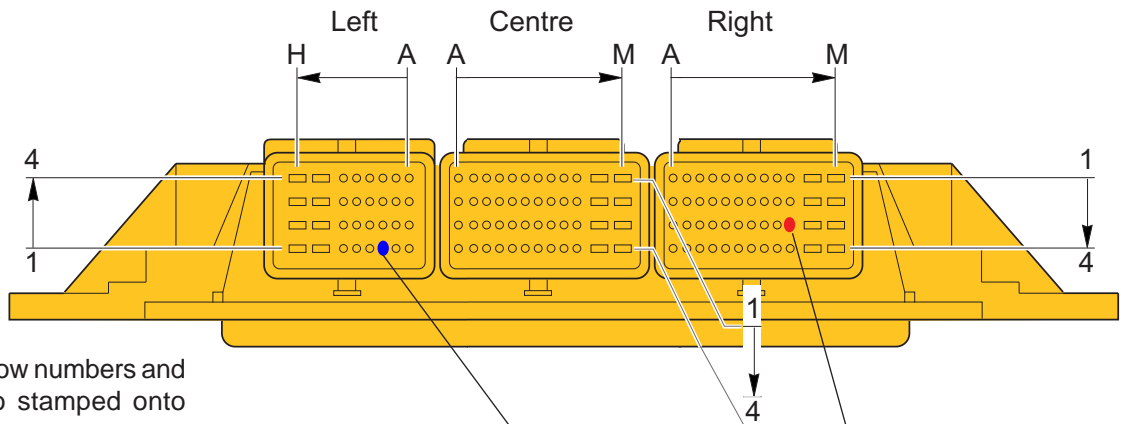

Column and Row numbers and digits are also stamped onto the ECM harness connector blocks as well as the actual harness multi-plugs

*Example of EMS pin information as displayed in an Elise Circuit Diagram*

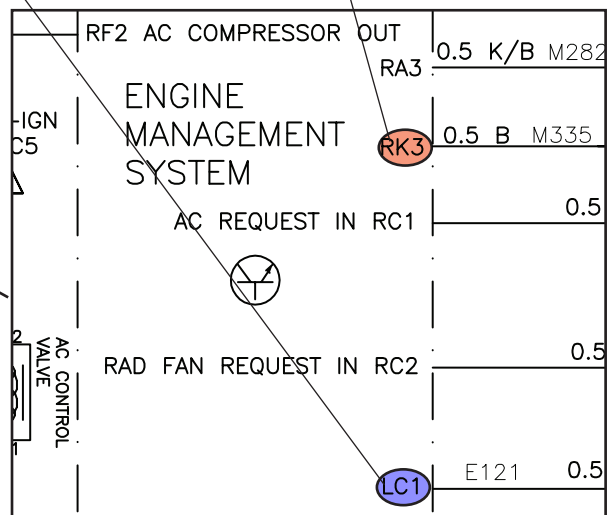



**TCU Harness connection and 'Pin out' identification**

The TCU uses 2 harness connector blocks. 1 multi-plug connector from the engine harness connecting to the left block (as viewed with the TCU in situ), with the other multi-plug connector from the main vehicle harness connecting to the right block. All harness connection information to the TCU are identified on the relevant circuit diagrams by:

- Left block (engine harness) Pin out numbers: 1 - 52
- Right block (main harness) Pin out numbers: 53 - 80

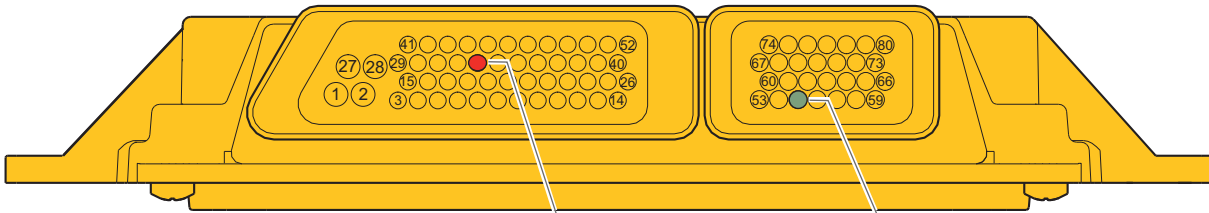

*Example of TCU pin information as displayed in an Exige S Circuit Diagram*

5)			20
6)	E131	0.5 S/K	33
7)	E132	0.5 B/G	47
8)	E133	0.5 B/R	40
9)	E134	0.5 Y/N	14
10)	E135	0.5 O/U	15
11)	E136	0.5 Y/P	25
12)	E137	0.5 Y/B	45
13)	E138	0.5 B/U	39
14)	E139	0.5 Y/U	13

TRANSMISSION CONTROLLER M558

**ECM - TCU location**

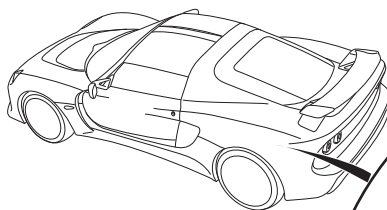

The ECM & TCU (if fitted) are located to the left hand side of the luggage compartment on the inner wheelarch panel, positioned forward of the battery behind the rear fusebox assembly.

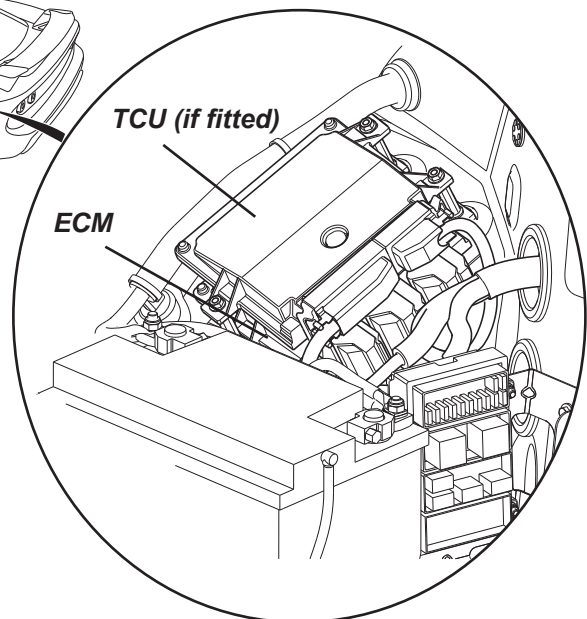



ECM fitment

The ECM is positioned underneath the TCU (if fitted) and is held in place above the LH wheelarch by a bracket/earthing plate.

The ECM is positioned underneath the TCU (if fitted) and is held in place above the LH wheelarch by a bracket/earthing plate.

The ECM and bracket/earthing plate are retained by 3 studs bonded to the inner wheelarch panel, the studs pass through machined holes within the bracket/earthing plate and ECM body and are retained with M5 flanged nyloc nuts (manual vehicles only).

For automatic vehicles spacer studs are fitted in place of the M5 nuts to position the TCU directly above the ECM.

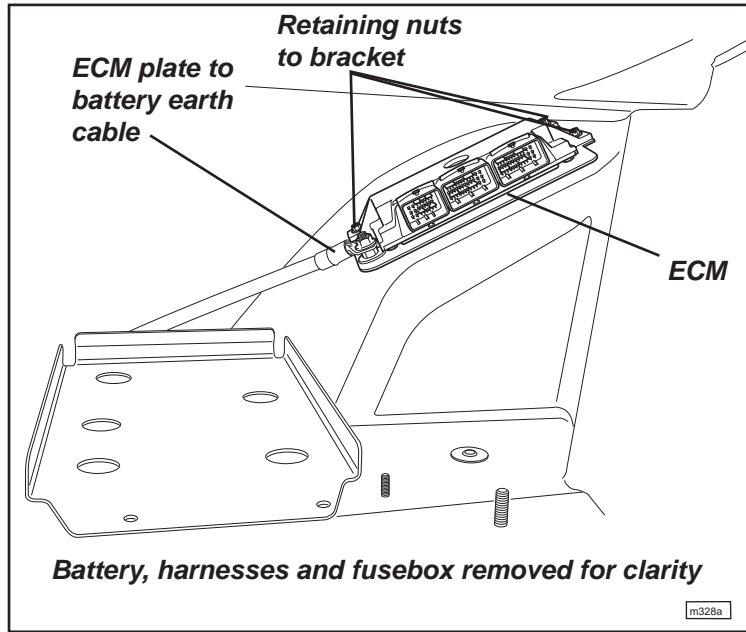

Care points for ECM removal:

**Note:** If it is necessary to renew an ECM then it is highly recommended that before removing the existing unit that you note down its current firmware calibration (Program or .CRP file number) and the variant code which can be obtained from the Lotus TechCentre vehicle information and EMS configuration screens.

**Before removing the ECM print out the vehicles performance history using TechCentre and file with the vehicles existing records or job card for future reference. This procedure should also be carried out before uploading a new programme as action of downloading a new level programme will delete the existing performance history.**

**Please note:** Lotus Cars may request a copy of a vehicles performance history in the event of a warranty enquiry which is related to potential powertrain abuse.

**Note:** Do not disconnect the battery or ECM harness connectors for at least 30 minutes after switching off the ignition to allow the engine management system and associated sensors to shut down in the correct sequence.

TCU

Removal:

- 1.Remove the vehicle battery, see sub-section MV.10 for further information.
- 2.Reposition the rear fusebox to gain access to the ECU, see sub-section MV.12 for further information.
- 3.Unclip and detach the 1 Engine and 1 Vehicle harness connectors from the TCU.
- 4.Release the M6 nyloc nuts and washers (3) securing the TCU to the ECM spacer studs.
- 5.The TCU can now be withdrawn from the vehicle.

Refitment:

Is the reverse of removal.

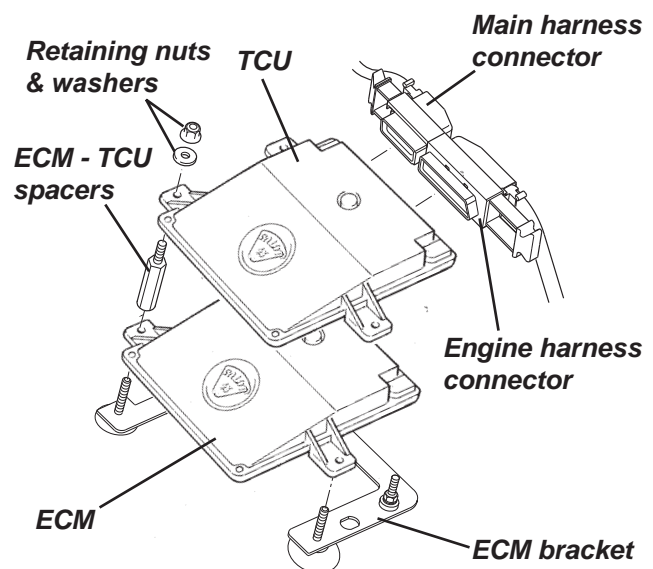



ECM

Removal:

Preparation - for manual vehicles follow steps 1 - 2 as shown for TCU removal on previous page, for automatic vehicles follow steps 1 - 5 as shown in TCU removal on previous page

6.Unclip and detach the 2 Engine and 1 Vehicle harness connectors from the ECM.

7.Release the 3 nuts securing the ECM to its wheelarch bracket.

The ECU can now be withdrawn from the vehicle.

To refit the ECM - TCU:

Reverse procedure from removal except for:

Check for any illuminated tell tales that may be displayed on the instrument pack and using Lotus TechCentre interrogate the ECM for any live or pending codes and erase.

Variant coding

Note: Although a new ECM cannot be fully variant coded by the dealer using Lotus TechCentre at this time (see page 59 for details), screen prints of variant code information are shown on the following page for reference.

ECM configuration screen 1 of 2 as shown on Lotus TechCentre

The screenshot shows the 'Instrument Cluster' configuration screen. Callouts provide details for several options:

- Instrument Cluster:** Select '11MY' for Elise/Edge which will take certain changes into account such as:
  - Clock in LCD display
  - Revised Tell-Tales.
  - Bosch ABS module with Lotus DPM option (Elise 1ZR powertrain only).
- Sport Button:** Set for 'True' for Evora with sport mode option & Elise Club Racer model.
- TCS Button:** Set for 'True' for Evora & Elise if Traction Control Button or Lotus DPM 'OFF' fitted.
- Yaw & Steering Angle Sensor:** Set to 'True' for all Evora and '11MY Elise with Bosch ABS modulator fitted with Lotus DPM option.
- Traction Control Level:**
  - Non (if not fitted at all)
  - Basic TC (if fitted to Pre- '11MY Elise with Kelsey Hayes ABS module)
  - TC & DTC (Not currently used)
  - ESP (For all Evora fitted with TC or Lotus DPM and '11MY Elise with Bosch ABS modulator and DPM option)
- Exhaust Silencer Bypass Valve:** Set to 'True' Evora S

Variant Code: D1C03E32224A0389

Note: Although it is possible to manually enter the variant coding from the option screens available there is a risk of making an error if this option is selected which may affect the display and or functionality of the instrument pack.

If the variant code has been recorded then it is recommended to use the guided routine option available on Lotus TechCentre.

If the variant coding has not been recorded or if the ECM will not communicate with Lotus TechCentre then it is advised to contact Lotus Cars Technical Publication Department stating the full vehicle VIN requesting the variant code information.

For further information see the 'Lotus TechCentre User Guide', which can be downloaded from the Lotus Dealer Portal at: <http://dealers>Aftersales>Miscellaneous Technical Information>TechCentre Information>.

MV.15 - IN CAR ENTERTAINMENT

The Exige S may be specified with various audio equipment options. All cars are fitted with a main wiring harness which includes:

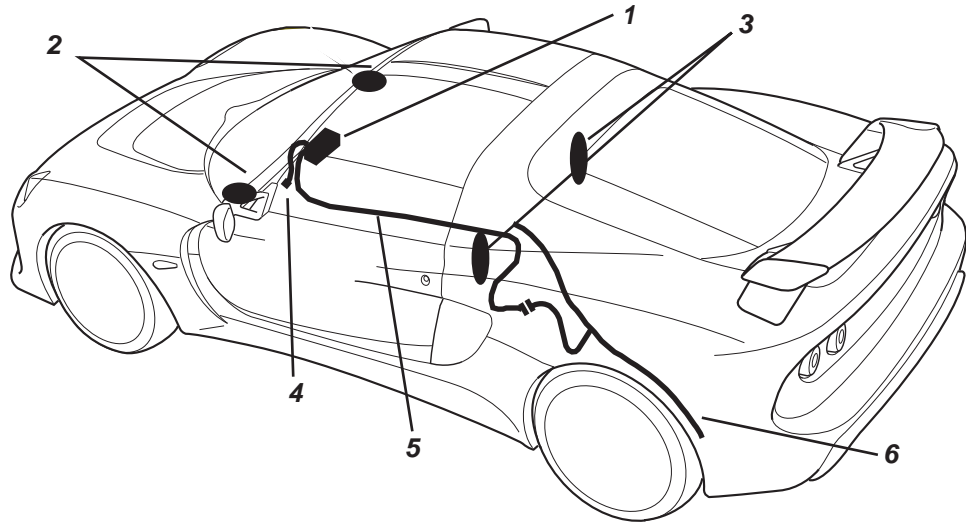

1. An ISO 16-way connector located behind the standard ISO size single DIN aperture in the dash panel/central face level vent panel trim to accommodate the current specification head unit.
2. Speaker wiring under dash panel for front speakers mounted in the LH/RH side fascia top panel.
3. Speaker wiring behind rear bulkhead trim panel for LH/RH rear speakers.
4. iPod adaptor lead plugged into the rear of audio head unit with the lead connector end terminating at the dashboard trinket tray.
5. Antenna cable connected to the rear of audio head unit, running along the centre of the cabin under the gear lever/handbrake tunnel trim and terminating at the engine bay bulkhead panel area.
6. An analogue di-pole aerial connected to the antenna cable which is routed and fixed to the inner surface of the LH clamshell wheelarch panel.

**Front speakers**

*Specifications:*

Alpine SPE - 1002 2-way co-axial; 75W max; 15W RMS; 4 ohms impedance; Frequency response 55Hz - 25kHz; Sensitivity 90dB / W (1m).

*Removal:*

1. Carefully prise of the speaker grille.
2. Using a suitable stubby or angled screwdriver release the screws (4) securing the speaker to the dash top fascia.
3. Raise the speaker away from the dash top, disconnect the speaker harness connector and withdraw the speaker.

*Refitment:*

Is the reverse of removal.

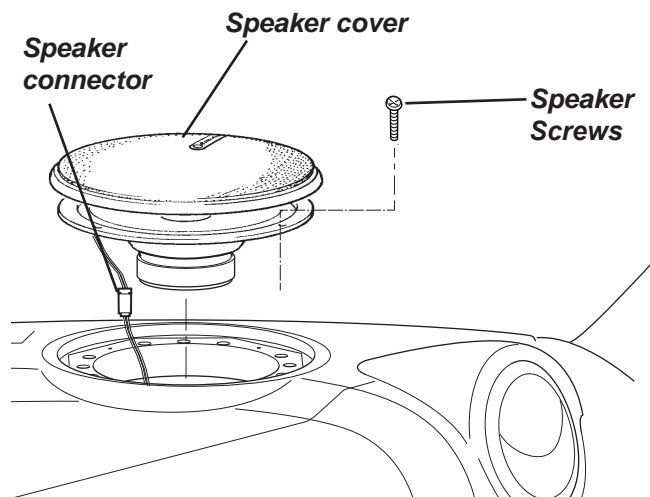





### Rear speakers

*Specifications:*

Alpine SPG-13C2 2-way; 200w max; 50W RMS; 4 ohms impedance; Frequency response: 82 Hz to 20 kHz; Sensitivity: 87.5dB / W (1m).

*Removal:*

1. Release the screws (4) securing the speaker to the bulkhead trim panel.
2. Pull the speaker away from the panel, disconnect the speaker harness connector and withdraw the speaker.

*Refitment:*

Is the reverse of removal.

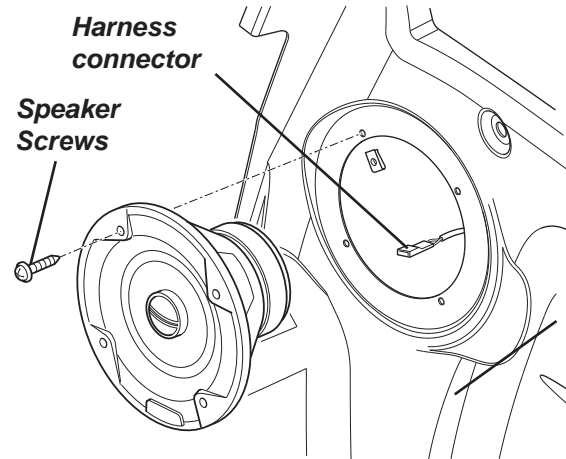

### Head unit

The dashboard and FLV (Face Level Vent) trim panel is designed to accept a standard single DIN (180 x 50 mm panel) size head unit and will utilise the mounting sleeve supplied with the unit to retain it in the dashboard.

At time of first publication of this service notes section the specified audio head unit for the Exige S is the Alpine CDE-171RR Radio/CD Player but this may be subject to change in the event of product obsolescence or future specification updates.

Certain markets i.e., Japan etc, may also have audio unit variations to ensure that they are compliant with their markets and requirements.

*Removal:*

1. Remove the unit's detachable front panel.
2. Insert the bracket keys (supplied with the unit) between the radio and mounting sleeve along the guides located either side of the unit to release it from its retaining tabs.
3. The unit can now be released from the mounting sleeve.
4. Withdrawn the radio from the FLV trim, disconnect the main harness connector and antenna cable from the rear of the unit.

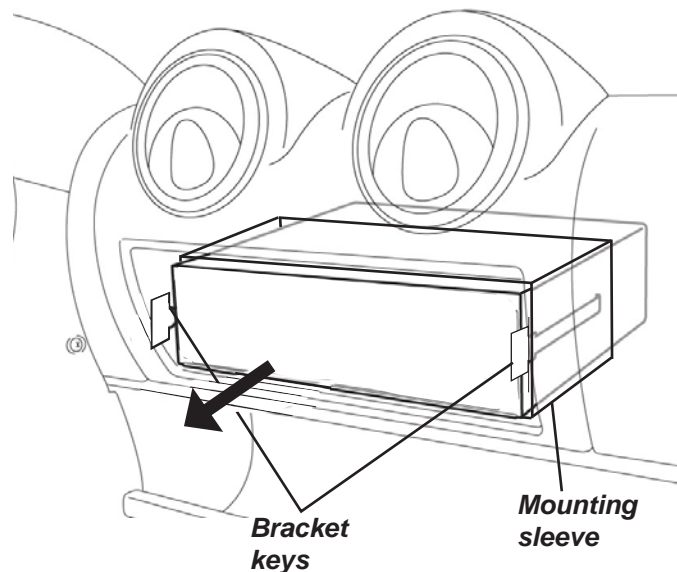

*Refitment:*

To prevent placing undue pressure on metal plate that retains its detachable front panel it is recommended to refit the unit with the front panel in place.

Connect the main harness connector to the terminal plug on the rear of the unit, ensuring that all other dashboard harness wiring is positioned away from the mounting sleeve so it cannot potentially become trapped when refitting the unit.

Slide the unit back into the dashboard/mounting sleeve until it clicks indicating that the units retaining tabs are locked in place and is now secure in the dashboard.



**Antenna/aerial cables**

**Antenna cable**

The radio antenna cable is connected to the rear of audio head unit, routed along the centre of the cabin under the gear lever/handbrake tunnel trim with the main harness, terminating at the engine bay bulkhead panel area at the NSR of the clamshell area near the seat belt anchor frame and the fuel evaporative canister.

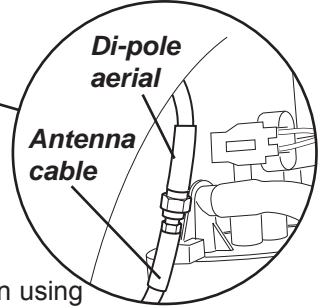
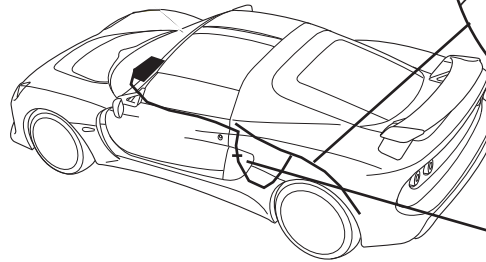
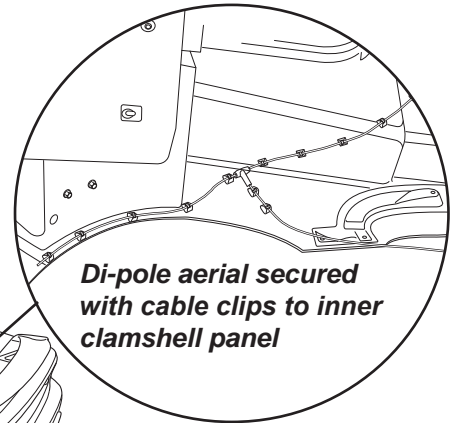

**Di-pole aerial**

The analogue di-pole aerial connected to the antenna cable which is routed and fixed to the inner surface of the LH clamshell wheelarch panel using cable clips bonded to panel.

**Cable clips**

8 evenly spaced clips (4 either side of the aerial 'T' section) are bonded in position using Loctite - 480 ensuring that aerial path runs in a straight line from the rear of the inner wheelarch up to the upper front of the clamshell by the rear seat belt anchor frame backstay.

3 Slightly larger clips are used to support the aerial from the 'T' section to the antenna connector; again the positioning of these clips is critical to ensure satisfactory radio reception. In the event that the either the aerial and or cable clips are renewed, it is essential that the aerial is routed correctly and any replacement cable clips are bonded back into their original positions.

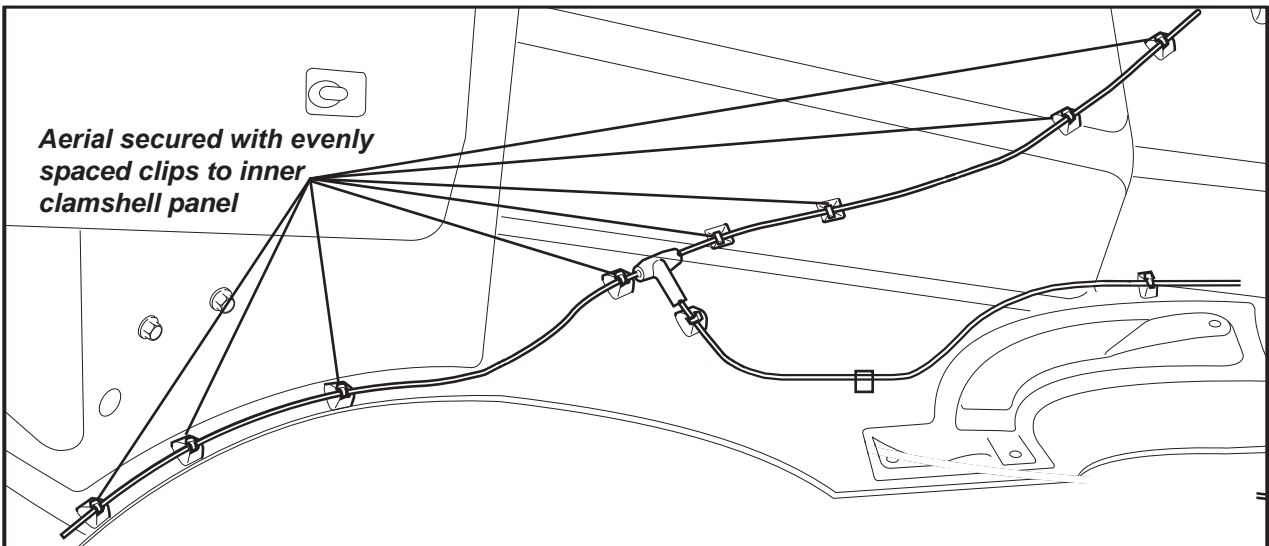

*Di-pole aerial removal:*

1. Disconnect the di-pole aerial from the antenna cable.
2. Remove the NSR wheelarch liner, refer to service notes section BT.5 for further information.
3. Release the aerial from the cable clips.

*Refitment:*

Is the reverse of removal.